

Induction Range, 36", 5 Zones with SmartZone, Self-cleaning

Series 9 | Contemporary

Stainless Steel



With large oven and cooktops that can be paired to create an expansive cook zone, this is a range made for those who love to cook.

- Five induction cooking zones, which can be joined to form SmartZones
- Convection oven with 4.9 cu.ft total capacity, nine oven functions including Roast, Aero Pastry™ with pizza mode and rapid proof for baking bread

- Non-tip full-extension shelves for safe removal of hot dishes
- High-temperature self-cleaning function breaks down food residue for an easy clean

DIMENSIONS

Height	35 3/4 - 37 1/4 "
Width	35 7/8 "
Depth	25 1/4 "

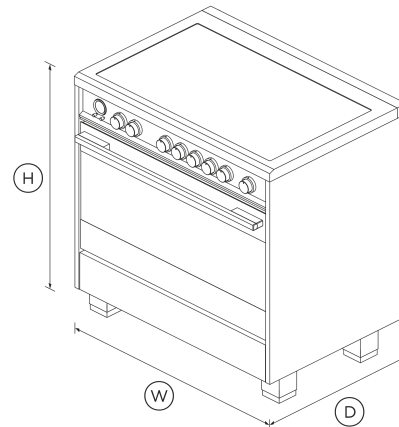

FEATURES & BENEFITS

Multi-Shelf Cooking

Our AeroTech™ system circulates air evenly throughout the entire oven so dishes on the top shelf turn out just as perfect as food cooking on the bottom shelf.

Quality and durability

Every detail has been carefully crafted. The solid, perfectly balanced soft-close door, durable cooktop and glowing halo dials all add up to an exceptional, premium range.

Power & control

Instant and immediate control from the highest to the gentlest heat. The finely tuned cooktop controls let you sear, stir fry or simmer a delicate sauce to perfection.

Easy To Clean

Cleaning up spills is effortless. Your cooktop simply needs a quick wipe to keep it looking good as new. The self-clean function breaks down food residue at a very high temperature, leaving a light ash that's easily removed with a damp cloth.

Even heat

Accurate, electronically-controlled oven heat ensures a great result every time.

Large Capacity Oven

The generous 4.9 cu.ft total capacity oven gives you plenty of space to cook multiple dishes at once, with enough room to fit a 32 lb turkey.

SPECIFICATIONS

Accessories (included)

2-pc grill system (Broil pan and Grill rack)	•
Broil pan	•
Full extension telescopic shelves	2 sets (part 578744)
Grill rack	true

Accessories (sold separately)

Kick strip, stainless steel (optional)	KICKOR36X1
Wok grate included	N/A

Capacity

Shelf positions	7
Total capacity	4.9 cu ft
Usable capacity	4.3 cu ft

Cleaning

Acid resistant graphite enamel	•
Drop down broil element	•
Drop down grill element	•
Flat easy clean glass surface	•
Pyrolytic proof shelf runners	•
Pyrolytic self-clean	•
Removable oven door	•
Removable shelf runners	•

Consumption

Energy usage	337kWh/year
--------------	--------------------

Controls

Audio feedback	•
Automatic cooking/minute timer	•
Automatic pre-set temperatures	•
Celsius/Fahrenheit temperature	•
Electronic capacitive touch controls	•

Electronic clock	•
High resolution display	•
Laser etched graphics	•
Precise electronic temperature control	•
Sabbath mode	•
Toughened fused glass graphics	•
Turned stainless steel clock buttons	•
Turned stainless steel clock crown (dial)	•
Turned stainless steel dials with illuminated halos	•

Main oven functions

Warm	•
------	---

Oven features

AeroTech™ technology	•
Automatic rapid pre-heat	•
Concealed element	•
Electronic oven control	•
Full extension telescopic sliding shelves	•
Internal light	4 x 25W halogen (2 side & 2 top)
Soft open/close door	•
True convection	•
Turned stainless steel clock dial	•
Twin cavity fans	•
Warming drawer	•

Oven functions

Aero Broil	•
Aero™ Bake	•
Aero™ Pastry with Pizza mode	•
Bake	•
Broil	•
Number of functions	9
Rapid proof	•
Roast	•
Self-clean function	•
True Aero	•
True convection	•

Oven performance

Broil power	4300 W
CoolTouch door	Quadruple glazed
Warming drawer power	220 W

Power requirements

Connection	4-prong [NEMA 14-50P power cord]
Service	40 A
Supply	120 / 240 V or 120 / 208 V, 60 Hz

Product dimensions

Depth	25 1/4 "
Height	35 3/4 - 37 1/4 "
Width	35 7/8 "

Rangetop features

Auto heat reduce	•
Dual zones	•
Gentle heat	•
Heat settings	9
Induction cooking technology	•
SmartZone	true
Zone bridging	•

Spill containment	3/8 gallon
Spillage auto off	•
Surface hot indicators	•

SKU	81710
-----	-------

The product dimensions and specifications in this page apply to the specific product and model. Under our policy of continuous improvement, these dimensions and specifications may change at any time. You should therefore check with Fisher & Paykel's Customer Care Centre to ensure this page correctly describes the model currently available. © Fisher & Paykel Appliances Ltd 2020

All appliances use energy, and energy usage typically generates carbon emissions. **Fisher & Paykel Appliances' In-use Energy Carbon Emissions Estimate** indicates carbon emissions from a product's in-use energy. This is calculated either annually or per cycle, using the product's market-specific energy label energy consumption data multiplied by the carbon emissions factor for energy in your country or region.

Our In-use Energy Carbon Emissions Estimate is designed to assist customers in making informed purchasing decisions when comparing different Fisher & Paykel products. For example, a heat pump dryer typically has a lower In-use Energy Carbon Emissions Estimate than a vented dryer.

Rangetop Performance

Centre	5500 W
Left front	3700 W
Left rear	3700 W
Number of cooking zones	5
PowerBoost	•

Other product downloads available at fisherpaykel.com

- [↓](#) Energy Label Dual Fuel / Induction Range
- [↓](#) Service & Warranty
- [↓](#) Installation Guide EN
- [↓](#) Installation Guide FR
- [↓](#) Revit Induction Range
- [↓](#) Rhino Induction Range
- [↓](#) Sketchup Induction Range
- [↓](#) User Guide Freestanding Range EN
- [↓](#) Guide d'utilisation FR

Where applicable:

Safety

ADA compliant	•
Advanced cooling system	•
Anti-tilt bracket	•
Balanced oven door	•
Catalytic venting system	•
Child lock	•
Full extension telescopic shelves	2 sets (part 578744)
Full extension telescopic sliding shelves	•
Non-tip shelves	•
Pan detection system	•
Safety time out	•
Spill containment	143.83 L



A PEACE OF MIND SALE
24 Hours 7 Days a Week Customer Support
 T 1.888.936.7872 W www.fisherpaykel.com