

Gas Range, 48", 8 Burners

Series 7 | Professional

Stainless Steel | Natural Gas



Size plus power. Eight burners deliver powerful 23,500 BTU heat, with two gas ovens for a combined 7.7 cu ft capacity.

- Top burner heat of 23,500 BTU, for seriously fast boiling
- Expansive 7.7 cu ft total oven capacity across two oven cavities
- Non-tip full-extension shelves in main cavity for safe removal of hot dishes

DIMENSIONS

Height	35 3/4 - 36 3/4 "
Width	47 7/8 "
Depth	29 1/8 "

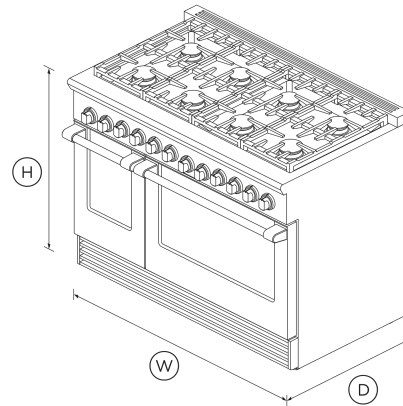

FEATURES & BENEFITS

Cooktop Power

Sealed Dual Flow Burners™ deliver cooktop power up to 23,500 BTU (NG models) for seriously fast boiling right down to a precise 140°F full surface simmer with the gentlest of flames.

Total Control

Precise control across high and low settings is delivered through the halo-illuminated cooktop dials. The ovens have true convection and electronic oven control for precise and consistent temperatures.

Easy To Clean

A sealed cooktop surface coupled with a commercial-style stainless steel finish means your cooktop simply needs a quick wipe to keep it looking good as new.

Instant Visibility

Control dials have halo-illumination glowing white – heating up; orange – temperature reached; red – self-cleaning mode. The oven is illuminated by two powerful incandescent lights.

Cooking Flexibility

The cooktop is designed for easy access to any burner with grates you can smoothly slide pots across. The oven is large enough to hold full size baking sheets.

Consistent Broiling

The Gas Range broiler provides an even heat that covers a very large surface area – perfect for browning a fully loaded oven tray.

SPECIFICATIONS

Accessories (sold separately)

Square handle option	AH-R48
----------------------	--------

Burner ratings

Maximum burner power	23500 BTU
Power back centre	18500BTU
Power back centre (2)	18500BTU
Power back left	18500BTU
Power back right	18500BTU
Power front centre	18500BTU
Power front centre (2)	18500BTU
Power front left	23500BTU
Power front right	23500BTU

Total cooktop power	158000 BTU
Capacity	
Shelf positions (main oven)	5
Shelf positions (second oven)	5
Controls	
Electric circuit	3 wire
Metal illuminated dials	•
Gas Requirements	
Fitting and pipe	½ NPT, min. 5/8" flex line
Supply Pressure (natural gas)	6" to 9" W.C
Main oven features	
Broil pan	•
Electronic oven control	•
Full extension telescopic racks	•
Infrared broiler	•
Internal light	•
Main oven functions	
Bake	•
Broil	•
Convection bake	•
Number of oven functions	3

Oven features	
Auto re-ignition system	•
Internal light	true
Power requirements	
Amperage	15 A
Rated current	15 A
Supply frequency	60 Hz
Product dimensions	
Depth	29 1/8 "
Depth (excluding handles)	2918 mm
Height	35 3/4 - 36 3/4 "
Width	47 7/8 "
Rangetop features	
Sealed range top	•
Vent trim included	•
Recommended Back Guards Ventilation	
Combustible situation	BGRV2-3048H
Minimum CFM	1200
Non combustible situation	BGRV2-3048 / BGRV2-1248
Recommended hood	HCB48-12_N (48" Professional Range Hood, Dual Blower)

Safety	
ADA compliant	•
Full extension telescopic sliding shelves	•
Secondary oven features	
3/4 Extension racks	2
Electronic oven control	•
Internal light	•
Secondary oven functions	
Bake	•
Number of secondary oven functions	2
Proof	•
SKU	71350
<p>The product dimensions and specifications in this page apply to the specific product and model. Under our policy of continuous improvement, these dimensions and specifications may change at any time. You should therefore check with Fisher & Paykel's Customer Care Centre to ensure this page correctly describes the model currently available. © Fisher & Paykel Appliances Ltd 2020</p>	
Other product downloads available at fisherpaykel.com	
↓	2D-DWG Gas Range
↓	2D-DXF Gas Range
↓	Archicad Gas Range

- [↓](#) Data Sheet Gas Range
- [↓](#) Service & Warranty
- [↓](#) Installation Guide EN / Guide d'installation FR
- [↓](#) Planning Guide Gas Range
- [↓](#) Revit Gas Range
- [↓](#) Rhino 5
- [↓](#) Sketchup Gas Range
- [↓](#) User Guide EN
- [↓](#) Guide d'installation FR

Where applicable:

All appliances use energy, and energy usage typically generates carbon emissions. **Fisher & Paykel Appliances' In-use Energy Carbon Emissions Estimate** indicates carbon emissions from a product's in-use energy. This is calculated either annually or per cycle, using the product's market-specific energy label energy consumption data multiplied by the carbon emissions factor for energy in your country or region.

Our In-use Energy Carbon Emissions Estimate is designed to assist customers in making informed purchasing decisions when comparing different Fisher & Paykel products. For example, a heat pump dryer typically has a lower In-use Energy Carbon Emissions Estimate than a vented dryer.



A PEACE OF MIND SALE
24 Hours 7 Days a Week Customer Support
T 1.888.936.7872 W www.fisherpaykel.com