

5kg Series 3 Vented Dryer, Auto Sensing, Full Reverse Tumbling

Series 3 | Vented

White



Dry your clothes efficiently, without over drying, in this vented dryer that's perfect for smaller households.

- Auto-sensing detects moisture level to prevent under or over drying
- Four fabric care cycles including Delicate and Everyday
- Full reverse tumbling to help dry garments quicker and more evenly

- Delay Start so you can set the start time to suit your schedule

DIMENSIONS

Height	830 mm
Width	600 mm
Depth	600 mm

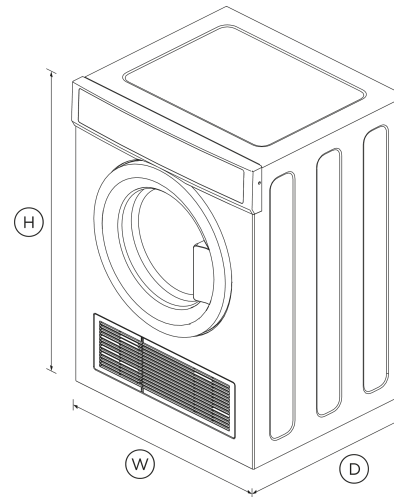

FEATURES & BENEFITS

Auto-Sensing Technology

Auto-sensing prevents over-drying by sensing moisture levels inside the drum and shutting off automatically. This helps clothes last for longer and reduces energy consumption.

Cares For Clothes

This model has four fabric care cycles including Delicate and Heavy, so all your items are taken care of. Select a cycle with the easy to use SmartTouch™ controls.

Simple Installation

Vent out either the front or the back of this dryer. A wall mounting kit is included and the control panel comes inverted.

Easy Loading

The robust dryer door features die cast metal hinges that open to a full 180° for easy access and loading.

SPECIFICATIONS

Consumption

Energy rating	2 star
Energy usage	220kWh/year
In-use energy carbon emissions estimate	143.3kgCO ₂ e/year

Dry Cycles

Everyday	•
Heavy	•

Features

Child/Keylock	•
Clean door lint filter reminder	•
Easy access lint filter	•
End of cycle signal	•
Progress indicator	•
Safety restart switch	•
Stainless steel drum	•

Performance

Auto sensing	•
Choice of front or rear venting	•
Dryness settings	3
Reverse tumbling	Semi reverse tumbling
Temperature settings	4

Product dimensions

Depth	600 mm
Height	830 mm
Width	600 mm

Warranty

Parts and labour	2 years
------------------	----------------

SKU 93277

The product dimensions and specifications in this page apply to the specific product and model. Under our policy of continuous improvement, these dimensions and specifications may change at any time. You should therefore check with Fisher & Paykel's Customer Care Centre to ensure this page correctly describes the model currently available. © Fisher & Paykel Appliances Ltd 2020

Other product downloads available at fisherpaykel.com

- [↓ Energy Label Vented Dryer](#)
- [↓ Service & Warranty](#)

- [↓ Installation Guide](#)
- [↓ User Guide](#)
- [↓ Installation Guide & User Guide Vented Clothes Dryer](#)

Where applicable:

All appliances use energy, and energy usage typically generates carbon emissions. **Fisher & Paykel Appliances' In-use Energy Carbon Emissions Estimate** indicates carbon emissions from a product's in-use energy. This is calculated either annually or per cycle, using the product's market-specific energy label energy consumption data multiplied by the carbon emissions factor for energy in your country or region.

Our In-use Energy Carbon Emissions Estimate is designed to assist customers in making informed purchasing decisions when comparing different Fisher & Paykel products. For example, a heat pump dryer typically has a lower In-use Energy Carbon Emissions Estimate than a vented dryer.



A PEACE OF MIND SALE
24 Hours 7 Days a Week Customer Support
 T 1300 650 590 W www.fisherpaykel.com