

Combination Microwave Oven, 24"

Series 5 | Contemporary

Stainless Steel



A flexible appliance that pairs the speed of microwave cooking with oven technology, which can crisp and brown as it cooks.

- 1.5 cu ft total capacity
- 12 cooking modes including Defrost, Popcorn and Reheat
- Use the 30" Microwave trim kit to integrate this microwave with your cabinetry
- Part of our suite of companion products, designed to match aesthetically for flexible configurations

DIMENSIONS

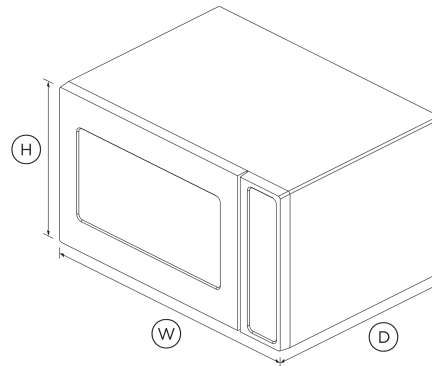

SPECIFICATIONS

Accessories (sold separately)

Matching Trim Kit CMOTTK-30-SS

Functions

- Defrost •
- Popcorn •

SKU 70997

The product dimensions and specifications in this page apply to the specific product and model. Under our policy of continuous improvement, these dimensions and specifications may change at any time. You should therefore check with Fisher & Paykel's Customer Care Centre to ensure this page correctly describes the model currently available. © Fisher & Paykel Appliances Ltd 2020

Other product downloads available at fisherpaykel.com

- [↓ 2D-DWG Combination Microwave Oven](#)
- [↓ 2D-DXF Combination Microwave Oven](#)
- [↓ Archicad Combination Microwave Oven](#)
- [↓ Archicad Combination Microwave Oven](#)
- [↓ Data Sheet Combination Microwave Oven](#)
- [↓ Service & Warranty](#)
- [↓ Installation Guide EN](#)
- [↓ Guide d'installation FR](#)
- [↓ Revit Combination Microwave Oven](#)
- [↓ Revit Combination Microwave Oven with 30" Trim](#)
- [↓ Revit Combination Microwave Oven](#)
- [↓ Revit Combination Microwave Oven with 30inch Trim](#)
- [↓ Rhino Combination Microwave Oven](#)
- [↓ Rhino Combination Microwave Oven with 30" Trim](#)
- [↓ Rhino Combination Microwave Oven](#)
- [↓ Rhino Combination Microwave Oven with 30inch Trim](#)
- [↓ Sketchup Combination Microwave Oven](#)
- [↓ Sketchup Combination Microwave Oven with 30" Trim](#)
- [↓ Sketchup Combination Microwave Oven](#)
- [↓ Sketchup Combination Microwave Oven](#)
- [↓ User Guide \(EN\)](#)
- [↓ Guide d'utilisation FR](#)

Where applicable:

All appliances use energy, and energy usage typically generates carbon emissions. **Fisher & Paykel Appliances' In-use Energy Carbon Emissions Estimate** indicates carbon emissions from a product's in-use energy. This is calculated either annually or per cycle, using the product's market-specific energy label energy consumption data multiplied by the carbon emissions factor for energy in your country or region.

Our In-use Energy Carbon Emissions Estimate is designed to assist customers in making informed purchasing decisions when comparing different Fisher & Paykel products. For example, a heat pump dryer typically has a lower In-use Energy Carbon Emissions Estimate than a vented dryer.



A PEACE OF MIND SALE
24 Hours 7 Days a Week Customer Support
T 1.888.936.7872 W www.fisherpaykel.com