

# Freestanding Refrigerator Freezer, 32", 17.1 cu ft, Ice & Water

Series 5 | Contemporary

Stainless Steel | Right Hinge



This stylish right hinge refrigerator has a large capacity and comes in timeless stainless steel.

- Bottom freezer drawer
- ActiveSmart™ helps keep food fresher for longer
- Brushed metal handles

## DIMENSIONS

|        |          |
|--------|----------|
| Height | 67 3/4 " |
| Width  | 31 1/8 " |
| Depth  | 27 3/8 " |

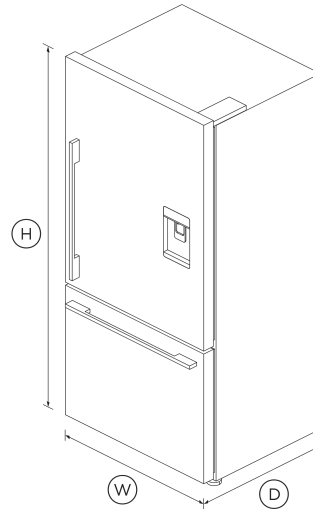

## FEATURES & BENEFITS

### ActiveSmart™ Foodcare

Every time you open your refrigerator, the temperature around your food changes. ActiveSmart™ foodcare adjusts airflow to create a stable temperature, helping your food stay fresher for longer.

### Easy Cleaning

No more stubborn dirty marks with our EZKleen feature for stainless steel fridges. Anti-fingerprint coating means you simply wipe clean any marks. Spill-safe secure glass shelves easily capture any drips or leaks.

### Design Quality

Our refrigerators are designed and built using quality materials. We use real stainless steel on our refrigerators and solid glass for shelving.

### WATER ON TAP

The slimline dispenser makes it easy to fill almost any sized jug or vessel with cool filtered water and doesn't take up any storage space in your refrigerator.

### Ice Maker

Fresh ice is always available for you in a dedicated freezer bin. Simply turn it off to free up freezer space or during busy times, you can boost ice production by up to 30%.

## SPECIFICATIONS

### Accessories (sold separately)

|  |                      |
|--|----------------------|
| Handle kit Contemporary round, aluminium | 25379                |
| Joiner Kit                               | 819264               |
| Surround Kit (Joined left/right pair)    | Part number<br>24476 |
| Surround Kit (Right Hand)                | 24475                |
| Water filter replacement                 | 847200 - FWC3        |

### Capacity

|                      |            |
|----------------------|------------|
| Total gross capacity | 17.1 cu ft |
| Volume freezer       | 4.8 cu ft  |
| Volume refrigerator  | 12.3 cu ft |

### Consumption

|              |             |
|--------------|-------------|
| Energy usage | 535kWh/year |
|--------------|-------------|

In-use energy carbon emissions estimate **66.0kgCO2e/year**

- Humidity control system
- Sabbath mode

**Features**

|                            |                                |
|----------------------------|--------------------------------|
| Adjustable door shelves    | <b>14</b>                      |
| Adjustable glass shelves   | <b>4</b>                       |
| Covered door shelves       | <b>2</b>                       |
| Door alarm                 | •                              |
| Fruit and vegetable bins   | <b>2</b>                       |
| LED lighting               | •                              |
| Smart appliance US CA      | •                              |
| SmartTouch control panel   | •                              |
| Stackable bottle holders   | <b>2</b>                       |
| Ultra slim water dispenser | •                              |
| Water Filter               | <b>Model number<br/>836848</b> |
| Wi-Fi connectivity         | •                              |

**Product dimensions**

|                                 |                 |
|---------------------------------|-----------------|
| Depth                           | <b>27 3/8 "</b> |
| Height                          | <b>67 3/4 "</b> |
| Minimum air clearance at rear   | <b>1 3/16 "</b> |
| Minimum air clearance each side | <b>1 3/16 "</b> |
| Width                           | <b>31 1/8 "</b> |

**Warranty**

|                             |                           |
|-----------------------------|---------------------------|
| Parts and labor             | <b>2 years</b>            |
| Sealed system parts & labor | <b>additional 3 years</b> |

SKU 26298

The product dimensions and specifications in this page apply to the specific product and model. Under our policy of continuous improvement, these dimensions and specifications may change at any time. You should therefore check with Fisher & Paykel's Customer Care Centre to ensure this page correctly describes the model currently available. © Fisher & Paykel Appliances Ltd 2020

**Other product downloads available at fisherpaykel.com**

- [↓](#) 2D-DWG Freestanding Refrigerator Freezer
- [↓](#) 2D-DXF Freestanding Refrigerator Freezer
- [↓](#) Data Sheet Freestanding Refrigerator Freezer
- [↓](#) Energy Label

- [↓](#) Service & Warranty
- [↓](#) Water Filter Replacement Instructions & Installation Guide EN
- [↓](#) Installation Guide - Quick Reference EN
- [↓](#) Installation Guide - Joiner Kit EN
- [↓](#) Guide d'installation - Instructions de Remplacement du Filtre à Eau FR
- [↓](#) Guide d'installation - kit de menuisier FR
- [↓](#) Installation Guide
- [↓](#) Guide d'installation FR
- [↓](#) User Guide
- [↓](#) Guide d'utilisation FR

**Where applicable:**

All appliances use energy, and energy usage typically generates carbon emissions. **Fisher & Paykel Appliances' In-use Energy Carbon Emissions Estimate** indicates carbon emissions from a product's in-use energy. This is calculated either annually or per cycle, using the product's market-specific energy label energy consumption data multiplied by the carbon emissions factor for energy in your country or region.

Our In-use Energy Carbon Emissions Estimate is designed to assist customers in making informed purchasing decisions when comparing different Fisher & Paykel products. For example, a heat pump dryer typically has a lower In-use Energy Carbon Emissions Estimate than a vented dryer.



**A PEACE OF MIND SALE**  
**24 Hours 7 Days a Week Customer Support**  
 T 1.888.936.7872 Wwww.fisherpaykel.com

**Performance**

- ActiveSmart™ Foodcare
- Adaptive defrost
- Frost free freezer