

Induction Range 30"

Series 9 | Contemporary

Stainless Steel



You'll love the instant response induction cooktop with multi-function oven, perfect for making a roast, baking bread and more.

- Four instant-response, cool-to-touch induction cooking zones
- Convection oven with 3.5 cu. ft total capacity and nine oven functions including
- Non-tip full-extension shelves for safe removal of hot dishes
- High-temperature self-cleaning function breaks down food residue for an easy clean

DIMENSIONS

Height	35 3/4 - 37 5/8 "
Width	29 7/8 "
Depth	25 1/4 "

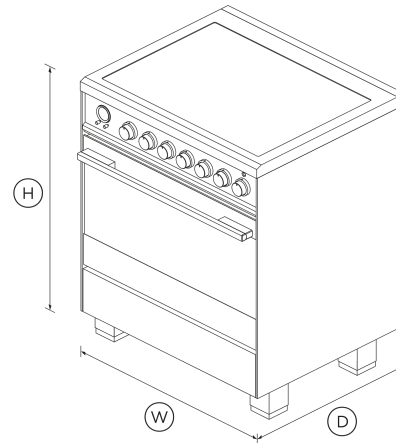

FEATURES & BENEFITS

Multi-Shelf Cooking

Our AeroTech™ system circulates air evenly throughout the entire oven so dishes on the top shelf turn out just as perfect as food cooking on the bottom shelf.

Quality And Durability

Every detail has been carefully crafted. The solid, perfectly balanced soft-close door, durable cooktop and glowing halo dials all add up to an exceptional, premium range.

Power & Control

Instant and immediate control from the highest to the gentlest heat. The finely tuned cooktop controls let you sear, stir fry or simmer a delicate sauce to perfection.

Easy To Clean

Cleaning up spills is effortless. Your cooktop simply needs a quick wipe to keep it looking good as new. The self-clean function breaks down food residue at a very high temperature, leaving a light ash that's easily removed with a damp cloth.

Even heat

Accurate, electronically-controlled oven heat ensures a great result every time.

SPECIFICATIONS

Accessories (included)

2-pc grill system (Broil pan and Grill rack)	•
Broil pan	•
Full extension telescopic shelves	2 sets (part 578776)

Accessories (sold separately)

Hob rear trim	3 1/8" (part 81656)
Kick strip, stainless steel (optional)	KICKOR30X1

Cleaning

Acid resistant graphite enamel	•
Drop down broil element	•
Drop down grill element	•
Flat easy clean glass surface	•
Pyrolytic proof shelf runners	•

- Pyrolytic self-clean
- Removable oven door
- Removable shelf runners

- Internal light **2 x 25W halogen (rear)**
- Soft open/close door
- True convection
- Turned stainless steel clock dial

Height **35 3/4 - 37 5/8 "**
 Width **29 7/8 "**

Consumption

Energy usage **337kWh/year**

Oven functions

- Aero™ Bake
- Aero™ Pastry with Pizza mode
- Number of functions **9**
- Rapid proof
- Roast
- True convection

Rangetop features

- Auto heat reduce
- Gentle heat
- Heat settings **9**
- Induction cooking technology

Controls

- Audio feedback
- Automatic cooking/minute timer
- Automatic pre-set temperatures
- Celsius/Fahrenheit temperature
- Electronic clock
- High resolution display
- Laser etched graphics
- Precise electronic temperature control
- Sabbath mode
- Toughened fused glass graphics
- Turned stainless steel clock buttons
- Turned stainless steel dials with illuminated halos

Oven performance

- Broil power **4050 W**
- CoolTouch door **Triple glazed**
- Warming drawer power **220 W**

Rangetop Performance

- Number of cooking zones **4**
- PowerBoost

Oven features

- AeroTech™ technology
- Automatic rapid pre-heat
- Concealed element
- Electronic oven control
- Full extension telescopic sliding shelves

Power requirements

- Connection **4-prong [NEMA 14-50P power cord]**
- Service **40 A**
- Supply **120 / 240 V or 120 / 208 V, 60 Hz**

Safety

- ADA compliant
- Advanced cooling system
- Anti-tilt bracket
- Balanced oven door
- Catalytic venting system
- Child lock
- CoolTouch door
- Full extension telescopic sliding shelves
- Non-tip shelves
- Pan detection system
- Safety time out
- Spill containment **68.13 L**
- Spill containment **1/8 gallon**
- Spillage auto off

Product dimensions

- Depth **25 1/4 "**

Surface hot indicators •

All appliances use energy, and energy usage typically generates carbon emissions. **Fisher & Paykel Appliances' In-use Energy Carbon Emissions Estimate** indicates carbon emissions from a product's in-use energy. This is calculated either annually or per cycle, using the product's market-specific energy label energy consumption data multiplied by the carbon emissions factor for energy in your country or region.

SKU

81722

Our In-use Energy Carbon Emissions Estimate is designed to assist customers in making informed purchasing decisions when comparing different Fisher & Paykel products. For example, a heat pump dryer typically has a lower In-use Energy Carbon Emissions Estimate than a vented dryer.

The product dimensions and specifications in this page apply to the specific product and model. Under our policy of continuous improvement, these dimensions and specifications may change at any time. You should therefore check with Fisher & Paykel's Customer Care Centre to ensure this page correctly describes the model currently available. © Fisher & Paykel Appliances Ltd 2020



A PEACE OF MIND SALE

24 Hours 7 Days a Week Customer Support

T 1.888.936.7872 W www.fisherpaykel.com

Other product downloads available at fisherpaykel.com

- [↓ 2D-DWG Induction Range](#)
- [↓ 2D-DXF Induction Range](#)
- [↓ Data Sheet Induction Range](#)
- [↓ Energy Label Dual Fuel / Induction Range](#)
- [↓ Service & Warranty](#)
- [↓ Installation Guide Freestanding Cooker EN](#)
- [↓ Guide d'installation FR](#)
- [↓ Revit Induction Range](#)
- [↓ Rhino Induction Range](#)
- [↓ Sketchup Induction Range](#)
- [↓ User Guide Freestanding Range EN](#)
- [↓ Guide d'utilisation FR](#)

Where applicable: