

# Freestanding Cooker, Induction, 90cm, 5 Zones with SmartZone

Series 7 | Classic

Stainless Steel



Heritage styling with contemporary performance in the large convection oven and induction cooktop, with SmartZone capability.

- Five cooking zones, with the ability to pair zones to create SmartZones
- Convection oven with 140L total capacity and nine oven functions including Pastry Bake with pizza mode and rapid proof for making bread

- Non-tip full-extension shelves for safe removal of hot dishes

## DIMENSIONS

Height	898 - 946 mm
Width	897 mm
Depth	600 mm

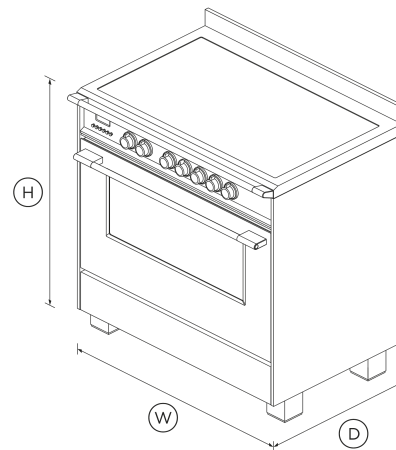

## FEATURES & BENEFITS

### Multi-Shelf Cooking

Our AeroTech™ system circulates air evenly throughout the entire oven so dishes on the top shelf turn out just as perfectly as food cooking on the bottom shelf.

### Quality And Durability

Every detail has been carefully crafted. The solid, perfectly balanced soft-close door, durable cooktop and glowing halo dials all add up to an exceptional, premium range.

### Power & Control

Instant and immediate control from the highest to the gentlest heat. The finely tuned cooktop controls let you sear, stir fry or simmer a delicate sauce to perfection.

### Even Heat

Accurate, electronically-controlled oven heat ensures a great result every time.

### Large Capacity Oven

The generous 140L total capacity oven gives you plenty of space to cook multiple dishes at once.

### Large, Flexible Cooking Area

SmartZone links two cooking zones and controls them as one, giving you the flexibility to use large pans and griddles and easily handle bigger food items such as a whole fish.

## SPECIFICATIONS

### Accessories (included)

Chromed shelf runners	1 set
Flat wire shelf	1
Full extension sliding shelves	1 set (part 578744)
Full extension telescopic shelves	1 set (part 578744)
Grill rack	true
Roasting dish	1
Step down wire shelf	•

### Accessories (sold separately)

Kick strip, stainless steel (optional) **KICKOR90X1**

**Capacity**

Shelf positions	<b>6</b>
Shelf positions (main oven)	<b>6</b>
Total capacity	<b>140 L</b>
Usable capacity (main oven)	<b>121 L</b>

**Cleaning**

Acid resistant graphite enamel	•
Drop down grill element	•
Flat easy clean glass surface	•
Removable oven door	•
Removable oven door inner glass	•
Removable shelf runners	•

**Controls**

Audio feedback	•
Automatic cooking/minute timer	•
Automatic pre-set temperatures	•
Celsius/Fahrenheit temperature	•
Electronic clock	•
Laser etched graphics	•
Precise electronic temperature control	•
Sabbath mode	•
Toughened fused glass graphics	•
Turned stainless steel clock buttons	•

**Installation Dimensions**

Installation cutout dimensions (Depth)	<b>600 mm</b>
Installation cutout dimensions (Width)	<b>900 mm</b>

**Oven features**

AeroTech™ technology	•
Automatic rapid pre-heat	•
Bright chromed, cast zinc dials with illuminated halos	•
Electronic oven control	•
Full extension telescopic sliding shelves	•
Internal light	<b>4 x 25W halogen (2 side &amp; 2 top)</b>
Soft open/close door	•
Storage drawer	•
True convection	•
Twin cavity fans	•

**Oven functions**

Bake	•
Classic bake	•
Fan bake	•
Fan forced	•
fanGrill	•
Grill	•
Number of functions	<b>9</b>
Pastry Bake with Pizza mode	•
Rapid proof	•
Roast	•
True convection	•

**Oven performance**

CoolTouch door	<b>Triple glazed</b>
----------------	----------------------

**Power requirements**

Amperage	<b>67 A</b>
Supply frequency	<b>50 Hz</b>
Supply voltage	<b>220-240 V</b>

**Product dimensions**

Depth	<b>600 mm</b>
Height	<b>898 - 946 mm</b>
Width	<b>897 mm</b>

**Rangetop features**

Auto heat reduce	•
Dual colour display	•
Gentle heat	•
Heat settings	<b>9</b>
Hob rail	•
Hob rear trim	<b>60 mm</b>
Induction cooking technology	•
SmartZone	<b>1</b>
Zone bridging	•

**Rangetop Performance**

Centre	<b>2300 W</b>
Left front	<b>1600 W</b>

Left rear **2100 W**  
 PowerBoost •

**Safety**

Advanced cooling system •  
 Anti-tilt bracket •  
 Balanced oven door •  
 Child lock •  
 CoolTouch door •  
 Full extension telescopic shelves **1 set (part 578744)**  
 Full extension telescopic sliding shelves •  
 Non-tip shelves •  
 Pan detection system •  
 Safety time out •  
 Spill containment **12 L**  
 Spillage auto off •  
 Surface hot indicators •

**Warranty**

Parts and labour **2 years**

SKU 81684

The product dimensions and specifications in this page apply to the specific product and model. Under our policy of continuous improvement, these dimensions and specifications may change at any time. You should therefore check with Fisher & Paykel's Customer Care Centre to ensure this page correctly describes the model currently available. © Fisher & Paykel Appliances Ltd 2020

**Other product downloads available at fisherpaykel.com**

- [↓](#) Service & Warranty
- [↓](#) Installation Guide Freestanding Cooker
- [↓](#) Installation Guide - Kick Strip
- [↓](#) Revit Induction Cooker
- [↓](#) Rhino Induction Cooker
- [↓](#) Sketchup Induction Cooker
- [↓](#) User Guide Freestanding Cooker
- [↓](#) User Guide

**Where applicable:**

All appliances use energy, and energy usage typically generates carbon emissions. **Fisher & Paykel Appliances' In-use Energy Carbon Emissions Estimate** indicates carbon emissions from a product's in-use energy. This is calculated either annually or per cycle, using the product's market-specific energy label energy consumption data multiplied by the carbon emissions factor for energy in your country or region.

Our In-use Energy Carbon Emissions Estimate is designed to assist customers in making informed purchasing decisions when comparing different Fisher & Paykel products. For example, a heat pump dryer typically has a lower In-use Energy Carbon Emissions Estimate than a vented dryer.



**A PEACE OF MIND SALE**  
**24 Hours 7 Days a Week Customer Support**  
 T 1300 650 590 Wwww.fisherpaykel.com