

30" Series 7 Contemporary Combi-Steam Oven

Series 7 | Contemporary

Stainless Steel



Designed for the home chef, our Combination Steam Oven simplifies the creation of healthy and delicious meals. It pairs seamlessly with companion products like the Vacuum Seal Drawer and Warming Drawer.

- 23 oven functions including Steam, Sous Vide, Air Fry and Crisp Regenerate
- Guided cooking makes it simple to cook using various functions, recipes, and food types

- Help reduce food waste by rejuvenating leftovers with steam for fresh-tasting roasts, and risottos and more
- Pair with our Vacuum Seal Drawer companion product for effortless Sous Vide preparation

DIMENSIONS

Height	23 9/16 "
Width	29 15/16 "
Depth	22 1/4 "

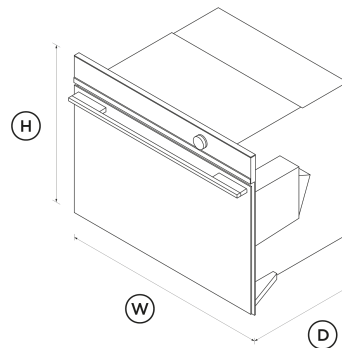

FEATURES & BENEFITS

Combination cooking

Elevate every ingredient with combination steam cooking. By blending dry convection heat with adjustable steam levels, you can preserve the delicate texture of seafood like salmon and snapper, maintain the essential vitamins and minerals in greens, and enhance the rich flavors of prime cuts of meat.

Mastery of temperature

Steam is eight times more efficient at conducting heat than convection, which means our combi steam oven can cook at reduced times and lower temperatures. It perfectly balances steam with convection heat, ensuring exceptional temperature accuracy for perfect roasting and crafting signature dishes.

Preserve flavor and nutrients

Perfect for delicate dishes like snapper or salmon, steam cooking preserves nutrients and texture, offering a healthier way to enjoy meals. With specialized steam functions, including Sous Vide, the combi steam oven brings out the best in every ingredient, ensuring your creations are both nutritious and delicious.

Cook with confidence

Using the 2.4" screen, you can cook with a favorite method, hero ingredient, cooking function, or recipe. Your oven will guide you through the steps, or change the temperature and heat type automatically, depending on your selection.

Reheat and restore

Revitalize your leftovers with our Steam Regenerate function, ensuring dishes like roast chicken and risotto maintain their freshness and flavor. For that just-baked quality in pastries, bread, and pizza, opt for our Crisp Regenerate setting, which reheats to keep every bite deliciously crispy.

Complementary design

Every detail has been carefully crafted from the finest materials to enhance your kitchen's aesthetic, perfectly suiting your design style. Pair it with our other Contemporary style appliances for the ultimate kitchen solution.

Steam clean

Keep your oven spotless with the natural power of steam. The steam clean feature helps tackle stubborn spills, allowing for a quick wipe-down.

SPECIFICATIONS

Accessories (included)

Broil pan	1
Broil rack	1
Descal solution	2
Perforated large steam dish	1
Perforated small steam dish	1
Step down wire shelf	1
Telescopic clip-on runners	1
Wire shelf	1

Capacity

Shelf positions	6
Total capacity	3 cu ft
Usable capacity	2.5 cu ft
Water tank capacity	47.3 oz

Cleaning

Acid resistant graphite enamel	•
Descal cycle	•
Drying cycle	•
Easy to clean interior	•
Removable oven door	•
Removable shelf runners	•

Removable water tank	•
Steam clean (oven)	•

Controls

Adjustable audio and display settings	•
Audio feedback	•
Automatic cooking/minute timer	•
Automatic pre-set temperatures	•
Celsius/Fahrenheit temperature	•
Delay start	•
Dial with illuminated halo	•
Electronic capacitive touch controls	•
Electronic clock	•
Electronic oven control	•
Food probe	•
Halogen lights	•
Multi-language display	true
Sabbath mode with Star K certification	•
Smart appliance	•
Soft close doors	•
Touch control glass interface	•
True convection oven	•
Voice control	•
Wireless temperature sensor compatible	•

Functions

Aero Broil	•
Aero™ Bake	•
Air fry	•

Bake	•
Classic bake	•
Crisp regenerate	•
Maxi Broil	•
Pastry Bake	•
Pizza bake	•
Roast	•
Slow cook	•
Sous vide	•
Steam	•
Steam clean (oven)	•
Steam defrost	•
Steam proof	•
Steam regenerate	•
True Aero	•
True Aero + High steam	•
True Aero + Low steam	•
True Aero + Medium steam	•
Vent bake	•
Warm	•

Performance

ActiveVent™ system	•
AeroTech™ technology	•
Automatic rapid pre-heat	•
Automatic sensor cooking	•
Temperature range	95-445

Power Requirements

Amperage	20 A
Supply frequency	60 Hz
Supply voltage	208 or 240 V

- [↓](#) Revit 2D Combination Steam Oven
- [↓](#) User Guide EN
- [↓](#) User Guide FR
- [↓](#) User Guide SP

Product Dimensions

Depth	22 1/4 "
Height	23 9/16 "
Width	29 15/16 "

Where applicable:

All appliances use energy, and energy usage typically generates carbon emissions. **Fisher & Paykel Appliances' In-use Energy Carbon Emissions Estimate** indicates carbon emissions from a product's in-use energy. This is calculated either annually or per cycle, using the product's market-specific energy label energy consumption data multiplied by the carbon emissions factor for energy in your country or region.

Our In-use Energy Carbon Emissions Estimate is designed to assist customers in making informed purchasing decisions when comparing different Fisher & Paykel products. For example, a heat pump dryer typically has a lower In-use Energy Carbon Emissions Estimate than a vented dryer.

SKU 84722

The product dimensions and specifications in this page apply to the specific product and model. Under our policy of continuous improvement, these dimensions and specifications may change at any time. You should therefore check with Fisher & Paykel's Customer Care Centre to ensure this page correctly describes the model currently available. © Fisher & Paykel Appliances Ltd 2020



A PEACE OF MIND SALE
24 Hours 7 Days a Week Customer Support

T 1.888.936.7872 W www.fisherpaykel.com

Other product downloads available at fisherpaykel.com

- [↓](#) 2D-DWG Combination Steam Oven
- [↓](#) 2D-DXF Combination Steam Oven
- [↓](#) Service & Warranty
- [↓](#) Installation Guide EN
- [↓](#) Installation Guide FR
- [↓](#) Installation Guide SP
- [↓](#) Planning Guide EN - Contemporary 30" Built-in Ovens and Companions
- [↓](#) Planning Guide FR - Contemporary 30" Built-in Ovens and Companions
- [↓](#) Planning Guide SP - Contemporary 30" Built-in Ovens and Companions