

Freestanding French Door Refrigerator Freezer, 36", 20.1 cu ft

Series 7 | Contemporary

Stainless Steel | French hinge



Designed for those who need plenty of flexible space for their cold and frozen food storage, with a stylish stainless steel finish.

- ActiveSmart™ helps keep food fresher for longer
- Bottom freezer drawer
- Brushed metal handles

DIMENSIONS

Height	70 3/4 "
Width	35 7/16 "
Depth	27 3/8 "

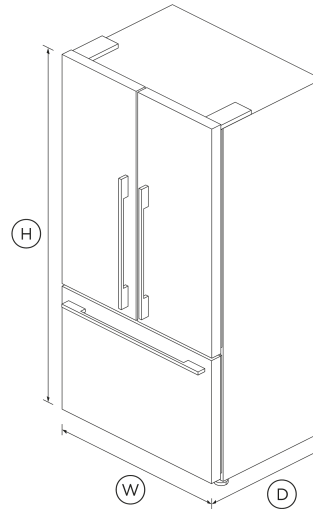

FEATURES & BENEFITS

ActiveSmart™ Foodcare

ActiveSmart™ Foodcare learns how you live. It's technology which understands how you use your refrigerator and adjusts temperature, airflow and humidity inside to help keep food fresher for longer.

Easy Cleaning

Spill-safe secure glass shelves easily capture any drips or leaks and prevent them from falling on items below.

Design Quality

Our refrigerators are designed and built using quality materials. We use real stainless steel on our refrigerators and solid glass for shelving.

Complementary Design

With their premium handle styling and stainless steel finish, our refrigerators are designed to match the rest of Fisher & Paykel's kitchen appliance family.

Humidity Control

Your fruit and veges need different environments. The humidity control slides in each storage bin create a microclimate that helps keep food fresher for longer.

SPECIFICATIONS

Accessories (sold separately)

Handle kit Contemporary round, aluminium	25377
--	-------

Capacity

Total gross capacity	20.1 L
Total gross capacity	20.1 cu ft
Volume freezer	5.5 cu ft
Volume refrigerator	14.6 cu ft

Consumption

Energy usage	448kWh/year
In-use energy carbon emissions estimate	55.2kgCO2e/year

Features

Adjustable door shelves	8
-------------------------	---

Adjustable glass shelves	3
Covered door shelves	2
Deli storage bins	2
Door alarm	•
Fruit and vegetable bins	2
Full width door shelves	2
LED lighting	•
Smart appliance US CA	•
SmartTouch control panel	•
Stackable bottle holders	4
Wi-Fi connectivity	•

Minimum air clearance each side	1 3/16 "
Width	35 7/16 "

Warranty

Parts and labor	2 years
Sealed system parts & labor	additional 3 years

SKU	26310
-----	-------

The product dimensions and specifications in this page apply to the specific product and model. Under our policy of continuous improvement, these dimensions and specifications may change at any time. You should therefore check with Fisher & Paykel's Customer Care Centre to ensure this page correctly describes the model currently available. © Fisher & Paykel Appliances Ltd 2020

Other product downloads available at fisherpaykel.com

- [↓](#) 2D-DWG Freestanding French Door Fridge Freezer
- [↓](#) 2D-DXF Freestanding French Door Fridge Freezer
- [↓](#) Archicad Freestanding French Door Fridge Freezer
- [↓](#) Data Sheet Freestanding French Door Fridge Freezer
- [↓](#) Energy Label
- [↓](#) Service & Warranty
- [↓](#) Installation Guide - Quick Reference EN
- [↓](#) Guide d'installation - Instructions de Remplacement du Filtre à Eau FR
- [↓](#) Installation Guide
- [↓](#) Guide d'installation FR
- [↓](#) Revit Freestanding French Door Fridge Freezer
- [↓](#) Rhino 5

[↓](#) Sketchup Freestanding French Door Fridge Freezer

Where applicable:

All appliances use energy, and energy usage typically generates carbon emissions. **Fisher & Paykel Appliances' In-use Energy Carbon Emissions Estimate** indicates carbon emissions from a product's in-use energy. This is calculated either annually or per cycle, using the product's market-specific energy label energy consumption data multiplied by the carbon emissions factor for energy in your country or region.

Our In-use Energy Carbon Emissions Estimate is designed to assist customers in making informed purchasing decisions when comparing different Fisher & Paykel products. For example, a heat pump dryer typically has a lower In-use Energy Carbon Emissions Estimate than a vented dryer.



A PEACE OF MIND SALE
24 Hours 7 Days a Week Customer Support
 T 1.888.936.7872 W www.fisherpaykel.com

Freezer Features

Bottle chill	•
Fast freeze	•
Ice trays	1

Performance

ActiveSmart™ Foodcare	•
Adaptive defrost	•
Frost free freezer	•
Humidity control system	•
Sabbath mode	•

Product dimensions

Depth	27 3/8 "
Height	70 3/4 "
Minimum air clearance at rear	1 3/16 "