

# Condensing Dryer, 8kg

Series 5 | Condensing

White



With no need to vent moisture outside your condensing dryer can be incorporated into any laundry design, for a beautiful laundry.

- 11 drying cycles including Delicate, Easy Iron and Rack Dry
- Auto-sensing detects moisture levels to prevent under or over drying
- No need for external venting, allowing your dryer to be placed anywhere in your home

## DIMENSIONS

Height	850 mm
Width	600 mm
Depth	645 mm

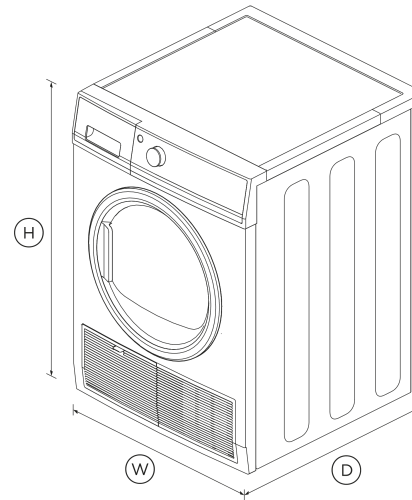

## FEATURES & BENEFITS

### Healthier Drying

Condensing technology drains water from the dryer into a tank. This reduces moisture and allergens released into your laundry compared with a front venting dryer. A healthier choice for allergy sufferers.

### Ease Of Use

This dryer has a cycle to suit every type of load including Delicate, Heavy and Freshen. Select a cycle with the easy-to-use SmartTouch™ control dial.

### Drying Rack

This model comes with a drying rack, perfect for those items that are too precious to tumble.

### Cares For Clothes

Auto-sensing prevents over-drying by sensing moisture levels inside the drum and shutting off automatically. This helps clothes last for longer and reduces energy consumption.

### Drum Light

A handy interior light turns on when you open the dryer door, providing improved visibility inside the drum.

### Perfect Pair

Fisher & Paykel washing machines and dryers are designed to match and look stylish together in your laundry, and can be stacked to offer you more storage space.

## SPECIFICATIONS

### Capacity

Total capacity	8 kg
----------------	------

### Dry Cycles

Air Dry	•
Air dry/Air fluff cycle	•
Bulky	•
Delicate	•
Easy Iron	•
Everyday	•
Heavy	•
Rack dry	•
Time to dry 30	•
Time to dry 60	•

Time to dry 90 •

Parts and labour **2 years**

**Features**

- Clean door lint filter reminder •
- Drum light •
- Drying rack •
- Easy access lint filter •
- End of cycle signal •
- Progress indicator •
- SmartTouch™ control dial •
- Stainless steel drum •
- Wrinkle free option •

SKU 98114

The product dimensions and specifications in this page apply to the specific product and model. Under our policy of continuous improvement, these dimensions and specifications may change at any time. You should therefore check with Fisher & Paykel's Customer Care Centre to ensure this page correctly describes the model currently available. © Fisher & Paykel Appliances Ltd 2020

**Other product downloads available at fisherpaykel.com**

- [↓ Service & Warranty](#)
- [↓ Installation Guide - Cavity Sizes](#)
- [↓ Installation Guide](#)
- [↓ User Guide](#)

**Performance**

- Auto sensing •
- Condensing •
- Dryness settings **5**
- Reverse tumbling •
- Temperature settings **4**
- Time dry **30, 60, 90 mins**

**Where applicable:**

All appliances use energy, and energy usage typically generates carbon emissions. **Fisher & Paykel Appliances' In-use Energy Carbon Emissions Estimate** indicates carbon emissions from a product's in-use energy. This is calculated either annually or per cycle, using the product's market-specific energy label energy consumption data multiplied by the carbon emissions factor for energy in your country or region.

Our In-use Energy Carbon Emissions Estimate is designed to assist customers in making informed purchasing decisions when comparing different Fisher & Paykel products. For example, a heat pump dryer typically has a lower In-use Energy Carbon Emissions Estimate than a vented dryer.

**Product dimensions**

- Depth **645 mm**
- Height **850 mm**
- Width **600 mm**

**Warranty**