

Double Oven, 30", 17 Function, Self-cleaning

Series 9 | Contemporary

Stainless Steel



A highlight of the Fisher & Paykel collection. Ideal for entertaining, with two large ovens to cook multiple dishes at once.

- Touchscreen guided cooking capability offers helpful tips for different food types as well as full recipes
- 4.1 + 4.1 cu ft total capacity across two oven cavities, with 17 oven functions
- Pyrolytic self-cleaning function breaks down food residue for an easy clean

- Non-tip, full extension sliding shelves for safe removal of hot dishes

DIMENSIONS

Height	48 1/2 "
Width	29 15/16 "
Depth	23 15/16 "

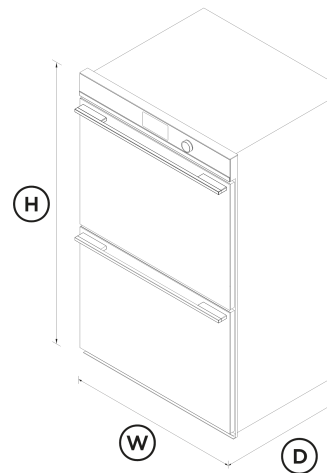

FEATURES & BENEFITS

Cook With Confidence

Using the large 5" touchscreen interface, you can cook with a favourite method, a hero ingredient, or a go-to cooking function or recipe. Your oven will guide you through the steps, or change the temperature and heat type automatically, depending on your selection.

Generous Capacity

With an incredible 4.1 cu ft total capacity in each oven, you can create several perfectly cooked dishes at once using multiple shelves.

Multi-Function Flexibility

Each function has been tailored, tested and perfected to ensure that no matter what you're cooking, you've got the right heat to match. Purchase our Wireless Temperature Sensor accessory and precisely monitor cooking in real time (accessory sold separately).

Exceptional Performance

AeroTech™ circulates heat evenly for a consistent temperature throughout the cavity, helping you ensure perfect results even when cooking on multiple shelves.

Self-Cleaning

Pyrolytic self-clean breaks down food residue at a very high temperature, leaving a light ash that's easily removed with a damp cloth. The enamel coated side racks don't need to be removed when using this function.

Design Freedom

Designed to fit seamlessly into your kitchen, this built-in oven features premium materials and detailing to support a cohesive, considered kitchen design.

Safe And Sound

The CoolTouch door features triple glazing and a cooling system that ensures it's safe to touch from the outside - protecting both your hands and the surrounding cabinetry.

SPECIFICATIONS

Accessories (included)

Pyrolytic proof shelf runners	•
Wired temperature sensor	1

Cleaning

- Acid resistant graphite enamel •
- Descalc cycle •
- Drying cycle •
- Pyrolytic self-clean •
- Removable oven door •
- Removable oven door inner glass •
- Removable shelf runners •
- Steam clean (oven) •

Controls

- Dial with illuminated halo •
 - Halogen lights •
 - Intuitive touchscreen display •
 - Multi-language display •
- UK English, US English, Simplified Chinese, Français, Español**
- Sabbath mode with Star K certification •
 - Smart appliance •
 - Soft close doors •
 - Wi-Fi connectivity •

Functions

- Aero Broil •
- Aero™ Bake •
- Air fry •
- Bake •
- Broil •
- Classic bake •

- Dehydrate •
- Maxi Broil •
- Number of functions **16**
- Pastry Bake •
- Pizza bake •
- Pyrolytic self-clean •
- Rapid proof •
- Roast •
- Slow cook •
- True Aero •
- Vent bake •
- Warm •

Performance

- ActiveVent™ system •
- AeroTech™ technology •

Power Requirements

- Amperage **39 A**

Product Dimensions

- Depth **23 15/16 "**
- Height **48 1/2 "**
- Width **29 15/16 "**

- SKU **82772**

The product dimensions and specifications in this page apply to the specific product and model. Under our policy of continuous improvement, these dimensions and specifications may change at any time. You should therefore check with Fisher & Paykel's Customer Care Centre to ensure this page correctly describes the model currently available. © Fisher & Paykel Appliances Ltd 2020

Other product downloads available at fisherpaykel.com

- [↓](#) 2D - DWG Double Oven
- [↓](#) 2D - DXF Double Oven
- [↓](#) ArchiCAD Oven
- [↓](#) Service & Warranty
- [↓](#) Installation Guide EN / Guide d'installation FR
- [↓](#) Installation Guide Wall Oven EN
- [↓](#) Planning Guide - Contemporary 30" Built-in Ovens and Companions
- [↓](#) Revit Oven
- [↓](#) Rhino Oven
- [↓](#) SketchUp Oven
- [↓](#) User Guide Oven EN
- [↓](#) User Guide Oven FR
- [↓](#) User Guide Oven SP

Where applicable:

All appliances use energy, and energy usage typically generates carbon emissions. **Fisher & Paykel Appliances' In-use Energy Carbon Emissions Estimate** indicates carbon emissions from a product's in-use energy. This is calculated either annually or per cycle, using the product's market-specific energy label energy consumption data multiplied by the carbon emissions factor for energy in your country or region.

Our In-use Energy Carbon Emissions Estimate is designed to assist customers in making informed purchasing decisions when comparing different Fisher & Paykel products. For example, a heat pump dryer typically has a lower In-use Energy Carbon Emissions Estimate than a vented dryer.



A PEACE OF MIND SALE
24 Hours 7 Days a Week Customer Support
T 1.888.936.7872 W www.fisherpaykel.com