

Freestanding Quad Door Refrigerator Freezer , 90.5cm, 538L

Series 7 | Contemporary

Stainless Steel | French hinge



Featuring three separate compartments, including an independent Variable Temperature Zone, for unbelievably flexible storage.

- Variable Temperature Zone lets you change a compartment to Fridge, Chill, Soft Freeze or Freezer for optimal storage
- ActiveSmart™ technology helps keep food fresher for longer by constantly maintaining the ideal temperature.

- Spacious bottom freezer with easy-slide internal drawers to separate storage

DIMENSIONS

Height	1790 mm
Width	905 mm
Depth	688 mm

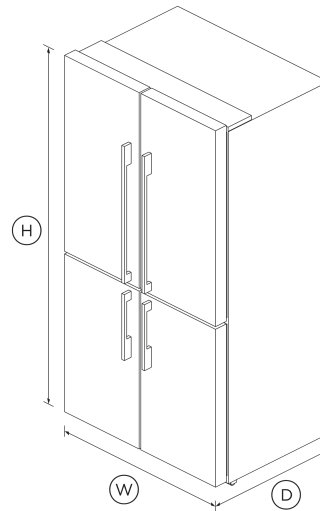

FEATURES & BENEFITS

Variable Temperature Zone

When it comes to optimal food preservation, one temperature does not fit all. Variable Temperature Zones give you full control over the way you care for food. At the touch of a button, easily convert the lower right compartment to Freezer, Soft Freeze, Chill or Fridge mode, to best suit different types of food. Adjust zones for maximum every day convenience, or change modes to provide additional chilling capacity for special occasions.

CHILL MODE

Keep ready-to-eat food fresher for longer with Chill Mode (-1.5 to 0°C). Chill Mode is a perfect solution for everyday life. It keeps meats, poultry and fish as cool as possible, retaining vital freshness and helps food retain its condition for around three times longer than Fridge Mode. It's also great for entertaining. Set a zone to Chill Mode to quickly bring beverages down to serving temperature.

SOFT FREEZE MODE

Soft freeze (-10 to -6°C) is perfect for food that will be consumed soon – but not right away. Set a zone to Soft Freeze Mode and enjoy optimal food storage and everyday convenience. Soft frozen food requires only a quick thaw rather than a full defrost. It is the ideal setting for easy portioning, such as cut loaves of bread, soups and even cured meats, or for serving straight from the compartment.

Activesmart™ Foodcare

ActiveSmart™ Foodcare learns how you live. It is technology which understands how you use your fridge and adjusts temperature, airflow and humidity inside to help keep food fresher for longer.

BEAUTY OF CHOICE

With the choice of stylish stainless steel or elegant black, you can choose the finish that complements your kitchen design best.

Design quality

Our refrigerators are designed and built using robust, quality materials, with stainless steel exteriors and solid glass for the interior shelving.

SPECIFICATIONS

Capacity

Total gross capacity	605 L
Volume	538 L
Volume freezer	98 L
Volume refrigerator	341 L
Volume variable temperature compartment	99 L

Consumption

Energy rating	4 star
Energy usage	396 kWh/year
In-use energy carbon emissions estimate	258.0kgCO2e/year

Features

Adjustable door shelves	6
Adjustable glass shelves	4
Cantilevered glass shelves	4
cantileveredGlassShelves	4
Covered door shelves	2
Door alarm	•
Front levelling feet	•
Fruit and vegetable bins	2
Full extension runners	•
LED lighting	•

Rear rollers	•
SmartTouch control panel	•
Stackable bottle holders	4

Freezer Features

Bottle chill	•
Door alarm	•
Fast freeze	•
Full extension clear bins	3
Ice bin and scoop	•
LED Lighting	•

Performance

ActiveSmart™ Foodcare	•
Automatic defrost	•
Frost free freezer	•
Humidity control system	•
Inverter controlled compressor	•
R600a refrigerant	•
Sabbath mode	•
Variable Temperature Compartment Performance	•
Variable temperature zones	1

Power requirements

Supply voltage	220 V
----------------	--------------

Product dimensions

Depth	688 mm
Height	1790 mm
Height to top of cabinet	1775 mm
Height to top of door	1790 mm
Minimum air clearance - at rear	30 mm
Minimum air clearance - each side	20 mm
Minimum air clearance - on top	20 mm
Width	905 mm

Warranty

Parts and labour	2 years
Sealed system parts only	5 years

SKU	26548
-----	--------------

The product dimensions and specifications in this page apply to the specific product and model. Under our policy of continuous improvement, these dimensions and specifications may change at any time. You should therefore check with Fisher & Paykel's Customer Care Centre to ensure this page correctly describes the model currently available. © Fisher & Paykel Appliances Ltd 2020

Other product downloads available at fisherpaykel.com

- [↓](#) 2D-DWG Freestanding Quad Door Fridge Freezer
- [↓](#) 2D-DXF Freestanding Quad Door Fridge Freezer
- [↓](#) Data Sheet Freestanding Quad Door Fridge Freezer
- [↓](#) Energy Label Refrigeration
- [↓](#) Service & Warranty

↓ Installation Guide Freestanding Quad Door Refrigerator Freezer

↓ User Guide Freestanding Refrigerator Freezer

Where applicable:

All appliances use energy, and energy usage typically generates carbon emissions. **Fisher & Paykel Appliances' In-use Energy Carbon Emissions Estimate** indicates carbon emissions from a product's in-use energy. This is calculated either annually or per cycle, using the product's market-specific energy label energy consumption data multiplied by the carbon emissions factor for energy in your country or region.

Our In-use Energy Carbon Emissions Estimate is designed to assist customers in making informed purchasing decisions when comparing different Fisher & Paykel products. For example, a heat pump dryer typically has a lower In-use Energy Carbon Emissions Estimate than a vented dryer.



A PEACE OF MIND SALE
24 Hours 7 Days a Week Customer Support
T 1300 650 590 W www.fisherpaykel.com