

Freestanding Refrigerator Freezer, 32", 17.1 cu ft, Ice

Series 5 | Contemporary

Stainless Steel | Left hinge



This stylish left hinge refrigerator is designed to fit flush with your cabinetry and comes in timeless stainless steel.

- ActiveSmart™ Foodcare technology helps keep food fresher for longer
- Flat door that fits flush with cabinetry
- Brushed metal handles

DIMENSIONS

Height	67 1/2 "
Width	31 3/32 "
Depth	27 3/8 "

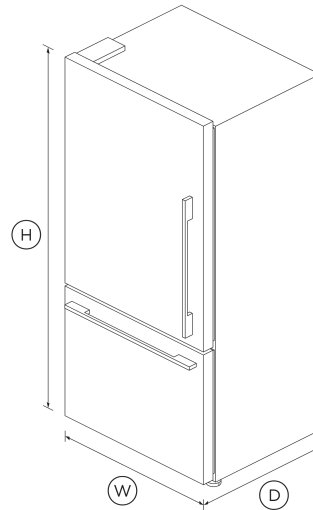

FEATURES & BENEFITS

Activesmart™ Foodcare

This refrigerator freezer adapts to daily use by cooling and defrosting only when needed. ActiveSmart™ Foodcare technology uses energy efficiently without compromising on food care.

Flexible Storage

Adjustable shelves and door storage give you plenty of room to stack and pack all your groceries. Storage bins give you full access inside when they're pulled open and can be easily removed to clean.

Humidity Control

Your fruit and veges need different environments to stay fresh. Humidity control in each storage bin allows you to maintain a microclimate that helps keep food fresher for longer.

Design Quality

Our fridges are designed and built using quality materials. We use real stainless steel on our fridges and solid glass for shelving.

Internal Ice Maker

Fresh ice is always available for you in a dedicated freezer bin. Simply turn it off to free up freezer space or during busy times, you can boost ice production by up to 30%.

Easy Cleaning

No more stubborn dirty marks with our EZKleen feature for stainless steel fridges. Anti-fingerprint coating means you simply wipe clean any marks. Spill-safe secure glass shelves easily capture any drips or leaks.

Easy to use

The SmartTouch control panel has been designed to be intuitive for ease to use, and is conveniently placed near the front of the fridge.

SPECIFICATIONS

Accessories (sold separately)

Joiner Kit	819264
Surround Kit (Joined left/right pair)	Part number 24476
Water filter replacement	847200 - FWC3

Capacity

Total gross capacity	17.1 cu ft
Volume freezer	4.8 cu ft
Volume refrigerator	12.3 cu ft

Consumption

Energy rating	Energy star
Energy usage	535kWh/year
In-use energy carbon emissions estimate	66.0kgCO2e/year

Features

Adjustable door shelves	14
Adjustable glass shelves	4
Covered door shelves	2
Door alarm	•
Front levelling feet	•
Fruit and vegetable bins	2
LED lighting	•
Rear rollers	•
Smart appliance	•
SmartTouch control panel	•
Stackable bottle holders	4
Wi-Fi connectivity	•

Freezer Features

Automatic ice maker	•
Bottle chill	•
Door alarm	•

Fast freeze	•
Ice bin and scoop	•
Ice Boost	•
Large plastic bins	•

Performance

ActiveSmart™ Foodcare	•
Adaptive defrost	•
Frost free freezer	•
Humidity control system	•
Inverter controlled compressor	•
Sabbath mode	•

Power requirements

Supply frequency	60 Hz
Supply voltage	110 - 120 V

Product dimensions

Depth	27 3/8 "
Height	67 1/2 "
Width	31 3/32 "

Warranty

Parts and labor	2 years
Sealed system parts & labor	additional 3 years

SKU **26293**

The product dimensions and specifications in this page apply to the specific product and model. Under our policy of continuous improvement, these dimensions and specifications may change at any time. You should therefore check with Fisher & Paykel's Customer Care Centre to ensure this page correctly describes the model currently available. © Fisher & Paykel Appliances Ltd 2020

Other product downloads available at fisherpaykel.com

- [↓ Energy Label](#)
- [↓ Service & Warranty](#)
- [↓ Water Filter Replacement Instructions & Installation Guide EN](#)
- [↓ Installation Guide - Joiner Kit EN](#)
- [↓ Guide d'installation - Instructions de Remplacement du Filtre à Eau FR](#)
- [↓ Guide d'installation - kit de menuisier FR](#)
- [↓ Installation Guide](#)
- [↓ Guide d'installation FR](#)
- [↓ Guide d'utilisation FR](#)
- [↓ User Guide](#)
- [↓ Guide d'utilisation FR](#)
- [↓ Guide d'utilisation FR](#)
- [↓ Installation & User Guide ActiveSmart Refrigerator EN](#)
- [↓ Guide d'installation et guide d'utilisation FR](#)

Where applicable:

All appliances use energy, and energy usage typically generates carbon emissions. **Fisher & Paykel Appliances' In-use Energy Carbon Emissions Estimate** indicates carbon emissions from a product's in-use energy. This is calculated either annually or per cycle, using the product's market-specific energy label energy consumption data multiplied by the carbon emissions factor for energy in your country or region.

Our In-use Energy Carbon Emissions Estimate is designed to assist customers in making informed purchasing decisions when comparing different Fisher & Paykel products. For example, a heat pump dryer typically has a lower In-use Energy Carbon Emissions Estimate than a vented dryer.



A PEACE OF MIND SALE
24 Hours 7 Days a Week Customer Support
T 1.888.936.7872 W www.fisherpaykel.com