

494L Series 5 Refrigerator Freezer, Ice & Water

Series 5 | Contemporary

Stainless Steel | Left hinge



With ample storage and a stylish stainless steel finish, for a timeless look.

- ActiveSmart™ technology helps keep food fresher for longer by constantly maintaining the ideal temperature.
- Spacious bottom freezer with easy-slide internal drawers to separate storage
- Door water dispenser and internal ice maker

DIMENSIONS

Height	1715 mm
Width	790 mm
Depth	695 mm

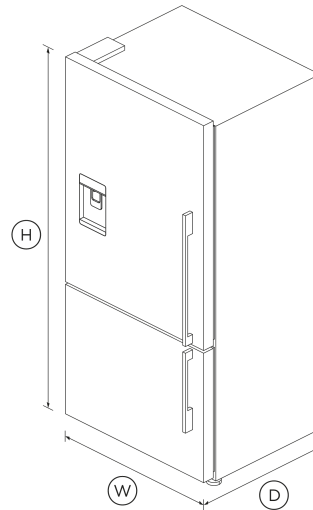

FEATURES & BENEFITS

ActiveSmart™ Foodcare

ActiveSmart™ Foodcare learns how you live. It is the technology that understands how you use your refrigerator and adjusts the temperature, airflow and humidity inside to help keep food fresher for longer.

Humidity Control

Your fruit and veges need different environments. The humidity control slides in each storage bin create a microclimate that helps keep food fresher for longer.

Clever Energy

Your fridge adapts to daily use by cooling and defrosting only when needed. This means your fridge uses the energy it needs without compromising on food care.

Design Quality

Our refrigerators are designed and built using quality materials. We use real stainless steel on our fridges and solid glass for shelving.

Easy Cleaning

No more permanent dirty marks with our EZKleen feature for stainless steel fridges. Anti-fingerprint coating means you simply wipe clean any marks. Spill-safe secure glass shelves easily capture any drips or leaks.

Ice Maker

Fresh ice is always available for you in a dedicated freezer bin. Simply turn it off to free up freezer space or during busy times, you can boost ice production by up to 30%.

Water Dispenser

The slimline dispenser makes it easy to fill almost any sized jug or vessel with cool filtered water and doesn't take up any storage space in your fridge.

SPECIFICATIONS

Accessories (sold separately)

Water filter replacement	847200 - FWC3
--------------------------	---------------

Capacity

Total gross capacity	519 L
Volume	494 L
Volume freezer	146 L
Volume refrigerator	348 L

Consumption

Energy rating	3.5 star
Energy usage	414kWh/year
In-use energy carbon emissions estimate	269.7kgCO2e/year

Features

Adjustable door shelves	4
Adjustable glass shelves	4
Covered door shelves	2
Door alarm	•
Front levelling feet	•
Fruit and vegetable bins	2
Full extension runners	•
Full width door shelves	2
LED lighting	•
Rear rollers	•
Single bottle holders	4
SmartTouch control panel	•
Ultra slim water dispenser	•

Freezer Features

Automatic ice maker	•
Bottle chill	•
Door alarm	•
Fast freeze	•
Freezer bins	3
Ice bin and scoop	•
Ice Boost	•
Large plastic bins	•

Slide Out Pastry Tray	•
Small plastic bins	•

Performance

ActiveSmart™ Foodcare	•
Adaptive defrost	•
External water dispenser	•
Frost free	•
Frost free freezer	•
Humidity control system	•
Inverter controlled compressor	•
Sabbath mode	•

Product dimensions

Depth	695 mm
Depth (including handles)	730 mm
Height	1715 mm
Height to top of cabinet	1715 mm
Minimum air clearance - at rear	30 mm
Minimum air clearance - each side	20 mm
Minimum air clearance - on top	50 mm
Width	790 mm

Warranty

Sealed system parts only	additional 3 years
SKU	26546

The product dimensions and specifications in this page apply to the specific product and model. Under our policy of continuous improvement, these dimensions and specifications may change at any time. You should therefore check with Fisher & Paykel's Customer Care Centre to ensure this page correctly describes the model currently available. © Fisher & Paykel Appliances Ltd 2020

Other product downloads available at fisherpaykel.com

- [↓ 2D-DWG Freestanding Refrigerator Freezer](#)
- [↓ 2D-DXF Freestanding Refrigerator Freezer](#)
- [↓ Archicad Freestanding Refrigerator Freezer](#)
- [↓ Data Sheet Freestanding Refrigerator Freezer](#)
- [↓ Service & Warranty](#)
- [↓ Water Filter Replacement Instructions & Installation Guide EN](#)
- [↓ Installation Guide](#)
- [↓ Revit Freestanding Refrigerator Freezer](#)
- [↓ Rhino Freestanding Refrigerator Freezer](#)
- [↓ Sketchup Freestanding Refrigerator Freezer](#)
- [↓ User Guide](#)
- [↓ User & Installation Guide ActiveSmart Refrigerator](#)

Where applicable:

All appliances use energy, and energy usage typically generates carbon emissions. **Fisher & Paykel Appliances' In-use Energy Carbon Emissions Estimate** indicates carbon emissions from a product's in-use energy. This is calculated either annually or per cycle, using the product's market-specific energy label energy consumption data multiplied by the carbon emissions factor for energy in your country or region.

Our In-use Energy Carbon Emissions Estimate is designed to assist customers in making informed purchasing decisions when comparing different Fisher & Paykel products. For example, a heat pump dryer typically has a lower In-use Energy Carbon Emissions Estimate than a vented dryer.



A PEACE OF MIND SALE

24 Hours 7 Days a Week Customer Support

T 1300 650 590 W www.fisherpaykel.com