

364L Series 5 Refrigerator Freezer

Series 5 | Contemporary

White | Right Hinge

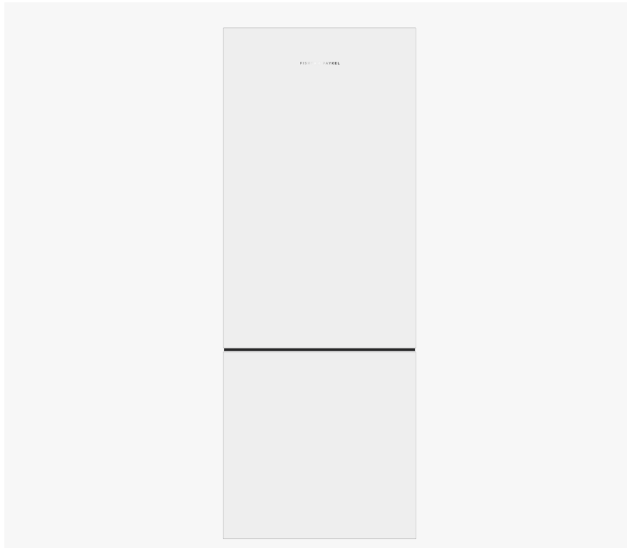

Compact and stylish in white stainless steel with concealed handles, complementing any kitchen design.

- ActiveSmart™ technology helps keep food fresher for longer by constantly maintaining the ideal temperature
- Top freezer for access to frozen goods without bending

DIMENSIONS

Height	1720 mm
Width	635 mm
Depth	695 mm

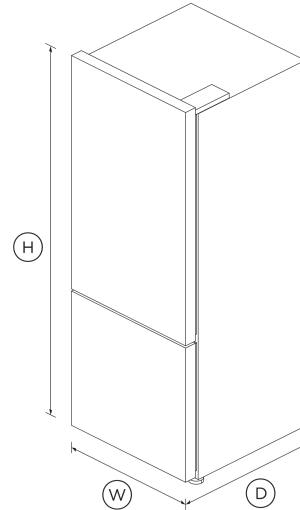

FEATURES & BENEFITS

ActiveSmart™ Foodcare

ActiveSmart™ Foodcare learns how you live. It's the technology that understands how you use your refrigerator and adjusts the temperature, airflow and humidity inside to help keep food fresher for longer.

Easy Cleaning

Spill-safe secure glass shelves easily capture any drips or leaks and prevent them from falling on items below.

Design Quality

Our refrigerators are designed and built using quality materials. We use real stainless steel, and solid glass for shelving as well as in our wine cabinet doors.

Simple Storage

This refrigerator is designed to make it simple for you to store, access and remove food. Storage bins give you full access inside when they're pulled open and can be easily removed to clean. Our flexible shelving also gives you more storage options.

Clever Energy

Your refrigerator adapts to daily use by cooling and defrosting only when needed. This means it uses the energy it needs without compromising on food care.

SPECIFICATIONS

Capacity

Total net volume **363L**

Consumption

Energy consumption **460kWh/year**
 Energy rating **2 ticks**

Features

Adjustable half width door shelves	2
Covered door shelves	2
Door alarm	•
Front levelling feet	•
Fruit and vegetable bins	2
Full extension runners	•

LED lighting	•
Rear rollers	•
SmartTouch control panel	•
Stackable bottle holders	2

Width **635 mm**

Freezer Features

Bottle chill	•
Door alarm	•
Fast freeze	•
Freezer bins	2
Slide Out Pastry Tray	•

Warranty

Parts and labour	2 years
Sealed system parts only	5 years

SKU 26192

The product dimensions and specifications in this page apply to the specific product and model. Under our policy of continuous improvement, these dimensions and specifications may change at any time. You should therefore check with Fisher & Paykel's Customer Care Centre to ensure this page correctly describes the model currently available. © Fisher & Paykel Appliances Ltd 2020

Performance

ActiveSmart™ Foodcare	•
Automatic defrost	•
Frost free	•
Humidity control system	•
R600a refrigerant	•
Sabbath mode	•

Other product downloads available at fisherpaykel.com

- [↓ 2D-DWG Freestanding Refrigerator Freezer](#)
- [↓ 2D-DXF Freestanding Refrigerator Freezer](#)
- [↓ Data Sheet Freestanding Refrigerator Freezer](#)
- [↓ Energy Label Freestanding Refrigerator Freezer](#)
- [↓ Service & Warranty](#)
- [↓ Installation Guide](#)
- [↓ User Guide](#)

Where applicable:

Product dimensions

Depth	695 mm
Height	1720 mm
Height to top of cabinet	1698 mm
Height to top of door	1720 mm
Minimum air clearance - at rear	30 mm
Minimum air clearance - each side	20 mm
Minimum air clearance - on top	50 mm

All appliances use energy, and energy usage typically generates carbon emissions. **Fisher & Paykel Appliances' In-use Energy Carbon Emissions Estimate** indicates carbon emissions from a product's in-use energy. This is calculated either annually or per cycle, using the product's market-specific energy label energy consumption data multiplied by the carbon emissions factor for energy in your country or region.

Our In-use Energy Carbon Emissions Estimate is designed to assist customers in making informed purchasing decisions when comparing different Fisher & Paykel products. For example, a heat pump dryer typically has a lower In-use Energy Carbon Emissions Estimate than a vented dryer.



A PEACE OF MIND SALE
24 Hours 7 Days a Week Customer Support
 T +65 6741 0777 W www.fisherpaykel.com