

# 2.4 cu ft Series 7 Front Loader Washer

Series 7 | Front Load

White



Ultimate performance and fabric care, this washer is powered by SmartDrive™ technology for a quicker, quieter wash

- 13 wash cycles including Sanitize, Sports and Wool wash, and extra wash features such as Steam and Time Saver
- With 'Add a Garment' function, allowing you to pause your wash and add an item
- Energy Star certified

- With our matching Condensing Dryer you have a perfect pair for your laundry

## DIMENSIONS

Height	33 1/4 - 33 5/8 "
Width	23 7/16 "
Depth	25 3/8 "

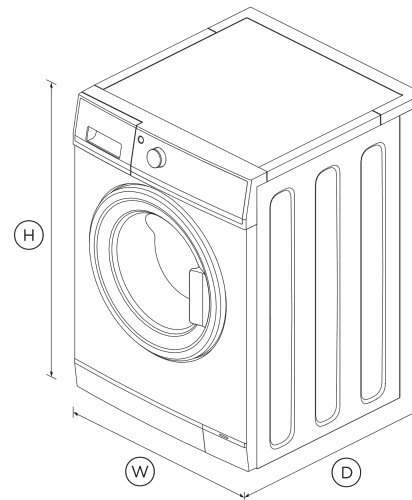

## FEATURES & BENEFITS

### Smartdrive(TM) Technology

SmartDrive™ Technology is a gentle, quiet, and efficient combination of smart electronics and a direct drive motor that senses the load to deliver better fabric care.

### Steam Clean

The Steam function opens up the fibers within the fabric, helping the wash cycle and cleaning agent to do their job more effectively. The result is a superior wash.

### Time Saver Option

The Time Saver option activates a special temperature profile and unique tumble sequence to speed things up when you are in a rush.

### Protect Your Woolens

Our Wool cycle has a Woolmark™ guarantee so you can wash your woolen garments with confidence.

### Drum Clean

The Drum Clean cycle flushes out the drum minimizing the chance of unwanted smells developing. A handy reminder to activate the Drum Clean function occurs after every 100 wash cycles.

### Add a Garment

The Add a Garment feature allows you to quickly add or remove any size garment mid cycle. Simply press the Add a Garment button and the door will unlock. If the drum water is too high, just enough will be drained out before the door is unlocked.

## SPECIFICATIONS

### Accessories (sold separately)

Stacking kit

### Capacity

Capacity

2.4 kg

Capacity

2.4 cu ft

**Consumption**

Energy rating	<b>Energy star</b>
Water consumption per cycle	<b>61L</b>

**Features**

- Add a garment (immediate door opening) •
- Anti-fungal door gasket •
- Auto out of balance correction •
- Child/Keylock •
- Delay start •
- Door and gasket flushing •
- Eco rinse •
- Extra rinse option •
- Flood protection •
- Hot and cold water inlets •
- Interior light •
- No Spin / Spin hold •
- Pre Wash •
- Progress indicator •
- SmartTouch™ control dial •
- Soak •
- Spin speeds **4**
- Stainless steel drum •
- Time saver function •
- Timed liquid detergent dispenser •
- Water supply **Hot & Cold**
- Water temperature controls **5**
- Wrinkle Free •

**Performance**

Detergent	<b>High efficiency</b>
Load sensing	•
Maximum spin speed	<b>1400 rpm</b>
Number of spin speeds	<b>4</b>
SmartDrive™ technology	•
Steam Care	•
Vortex wash	•

**Product dimensions**

Depth	<b>25 3/8 "</b>
Height	<b>33 1/4 - 33 5/8 "</b>
Width	<b>23 7/16 "</b>

**Warranty**

Parts and labor	<b>2 years</b>
Parts only SmartDrive™ motor	<b>10 years</b>

**Wash Cycles**

- Bulky •
- Cottons •
- Customise cycle •
- Delicate •
- Drum Clean •
- Everyday •
- Heavy •
- Number of wash cycles **13**
- Quick 30 •

- Rinse •
- Spin •
- Sports •
- Wool •

SKU 96235

The product dimensions and specifications in this page apply to the specific product and model. Under our policy of continuous improvement, these dimensions and specifications may change at any time. You should therefore check with Fisher & Paykel's Customer Care Centre to ensure this page correctly describes the model currently available. © Fisher & Paykel Appliances Ltd 2020

**Other product downloads available at fisherpaykel.com**

- [↓](#) Service & Warranty
- [↓](#) Guide d'installation FR
- [↓](#) Installation Guide EN
- [↓](#) Planning Guide Front Load Washer
- [↓](#) Guide d'utilisation FR
- [↓](#) Guide d'utilisation FR
- [↓](#) User Guide

**Where applicable:**

All appliances use energy, and energy usage typically generates carbon emissions. **Fisher & Paykel Appliances' In-use Energy Carbon Emissions Estimate** indicates carbon emissions from a product's in-use energy. This is calculated either annually or per cycle, using the product's market-specific energy label energy consumption data multiplied by the carbon emissions factor for energy in your country or region.

Our In-use Energy Carbon Emissions Estimate is designed to assist customers in making informed purchasing decisions when comparing different Fisher & Paykel products. For example, a heat pump dryer typically has a lower In-use Energy Carbon Emissions Estimate than a vented dryer.



**A PEACE OF MIND SALE**  
**24 Hours 7 Days a Week Customer Support**  
T 1.888.936.7872 W [www.fisherpaykel.com](http://www.fisherpaykel.com)