

5kg Series 3 Vented Dryer, Auto Sensing, Full Reverse Tumbling

Series 3 | Vented

White



Dry your clothes efficiently, without over drying, in this vented dryer that's perfect for smaller households.

- Four dry cycles including Delicate, Heavy and Everyday
- Auto-sensing detects moisture levels to prevent under or over drying
- Full reverse tumbling for an even dry and less tangling of clothes

- Comes with wall brackets, making it easy to hang for a tidy laundry

DIMENSIONS

Height	830 mm
Width	600 mm
Depth	600 mm

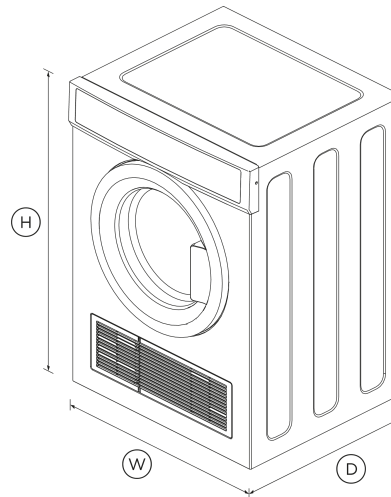

FEATURES & BENEFITS

Cares For Clothes

Auto-sensing prevents over-drying by sensing moisture levels inside the drum and shutting off automatically. This helps clothes last for longer and reduces energy consumption.

Easy Loading

The door opens a full 180° for easy access and loading.

SPECIFICATIONS

Consumption

Energy rating	2 star
Energy usage	220kWh/year
In-use energy carbon emissions estimate	143.3kgCO2e/year

Dry Cycles

Everyday	•
Heavy	•
Time dry	•

Features

Child/Keylock	•
Clean door lint filter reminder	•
Easy access lint filter	•
End of cycle signal	•
Progress indicator	•
Safety restart switch	•
Stainless steel drum	•

Performance

Auto sensing	•
Choice of front or rear venting	•
Dryness settings	3
Reverse tumbling	Full reverse tumbling
Temperature settings	4

Product dimensions

Depth	600 mm
Height	830 mm
Width	600 mm

SKU	93270
-----	-------

The product dimensions and specifications in this page apply to the specific product and model. Under our policy of continuous improvement, these dimensions and specifications may change at any time. You should therefore check with Fisher & Paykel's Customer Care Centre to ensure this page correctly describes the model currently available. © Fisher & Paykel Appliances Ltd 2020

Other product downloads available at fisherpaykel.com

- [↓](#) Energy Label Vented Dryer
- [↓](#) Service & Warranty
- [↓](#) Installation Guide
- [↓](#) User Guide
- [↓](#) Installation Guide & User Guide Vented Clothes Dryer

Where applicable:

All appliances use energy, and energy usage typically generates carbon emissions. **Fisher & Paykel Appliances' In-use Energy Carbon Emissions Estimate** indicates carbon emissions from a product's in-use energy. This is calculated either annually or per cycle, using the product's market-specific energy label energy consumption data multiplied by the carbon emissions factor for energy in your country or region.

Our In-use Energy Carbon Emissions Estimate is designed to assist customers in making informed purchasing decisions when comparing different Fisher & Paykel products. For example, a heat pump dryer typically has a lower In-use Energy Carbon Emissions Estimate than a vented dryer.



A PEACE OF MIND SALE
24 Hours 7 Days a Week Customer Support
T 1300 650 590 W www.fisherpaykel.com