

# Gas Range, 30", 5 Burners, LPG

Series 7 | Professional

Stainless Steel | LPG



Professional style and performance, with powerful burners delivering high heat or the most gentle simmer.

- Top burner heat of 19,000 BTU, for seriously fast boiling
- Gas oven with 4.6 cu ft total capacity
- Non-tip full-extension shelves for safe removal of hot dishes

## DIMENSIONS

Height	35 3/4 - 36 3/4 "
Width	29 7/8 "
Depth	29 1/8 "

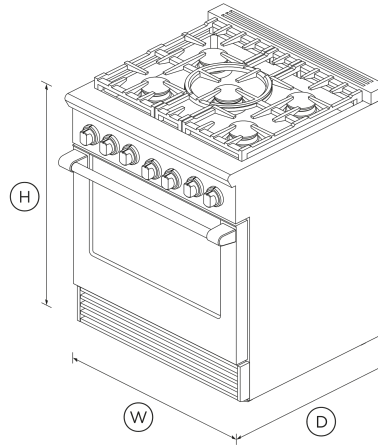

## FEATURES & BENEFITS

### Cooktop Power

Sealed Dual Flow Burners™ deliver cooktop power up to 23,500 BTU (NG models) for seriously fast boiling right down to a precise 140°F full surface simmer with the gentlest of flames.

### Total Control

Precise control across high and low settings is delivered through the halo-illuminated cooktop dials. The ovens have true convection and electronic oven control for precise and consistent temperatures.

### Easy To Clean

A sealed cooktop surface coupled with a commercial-style stainless steel finish means your cooktop simply needs a quick wipe to keep it looking good as new.

### Instant Visibility

Control dials have halo-illumination glowing white – heating up; orange – temperature reached; red – self-cleaning mode. The oven is illuminated by two powerful incandescent lights.

### Cooking Flexibility

The cooktop is designed for easy access to any burner with grates you can smoothly slide pots across. The oven is large enough to hold full size baking sheets.

### Design Quality

This range has been carefully crafted in every detail from performance to durability using quality materials.

## SPECIFICATIONS

### Accessories (sold separately)

Square handle option	AH-R30
Wok grate included	Yes

### Burner ratings

Maximum burner power	19000 BTU
Power back left	11500BTU
Power back right	11500BTU
Power centre	19000BTU
Power front left	15000BTU
Power front right	15000BTU
Total cooktop power	72000 BTU

<b>Capacity</b>	
Shelf positions (main oven)	5

<b>Controls</b>	
Electric circuit	3 wire
Metal illuminated dials	.

<b>Gas Requirements</b>	
Fitting and pipe	½ NPT, min. ⅝" flex line
Supply Pressure (LPG)	11" to 14" W.C

<b>Oven features</b>	
Auto re-ignition system	.
Broil pan	.
Electronic oven control	.
Full extension telescopic sliding shelves	.
Infrared Broiler	.
Internal light	true

<b>Oven functions</b>	
Bake	.
Broil	.
Convection bake	.
Number of functions	3

**Power Requirements**

Rated current	15 A
Supply frequency	60 Hz

**Product Dimensions**

Depth	29 1/8 "
Depth (excluding handles)	2918 mm
Height	35 3/4 - 36 3/4 "
Width	29 7/8 "

**Rangetop features**

Sealed range top	.
Vent trim included	.

**Safety**

ADA compliant	.
Full extension telescopic sliding shelves	.

SKU	71359
-----	-------

The product dimensions and specifications in this page apply to the specific product and model. Under our policy of continuous improvement, these dimensions and specifications may change at any time. You should therefore check with Fisher & Paykel's Customer Care Centre to ensure this page correctly describes the model currently available. © Fisher & Paykel Appliances Ltd 2020

Other product downloads available at [fisherpaykel.com](http://fisherpaykel.com)

- [↓ 2D-DWG Gas Range](#)
- [↓ 2D-DXF Gas Range](#)
- [↓ Archicad Gas Range](#)
- [↓ Data Sheet Gas Range](#)
- [↓ Service & Warranty](#)
- [↓ Installation Guide EN / Guide d'installation FR](#)
- [↓ Planning Guide Gas Range](#)
- [↓ Revit Gas Range](#)
- [↓ Rhino 5](#)
- [↓ Sketchup Gas Range](#)
- [↓ User Guide EN](#)

**Where applicable:**

All appliances use energy, and energy usage typically generates carbon emissions. **Fisher & Paykel Appliances' In-use Energy Carbon Emissions Estimate** indicates carbon emissions from a product's in-use energy. This is calculated either annually or per cycle, using the product's market-specific energy label energy consumption data multiplied by the carbon emissions factor for energy in your country or region.

Our In-use Energy Carbon Emissions Estimate is designed to assist customers in making informed purchasing decisions when comparing different Fisher & Paykel products. For example, a heat pump dryer typically has a lower In-use Energy Carbon Emissions Estimate than a vented dryer.



**A PEACE OF MIND SALE**  
**24 Hours 7 Days a Week Customer Support**  
 T 1.888.936.7872 W [www.fisherpaykel.com](http://www.fisherpaykel.com)