

Freestanding French Door Refrigerator Freezer, 32", 17 cu ft, Ice & Water

Series 7 | Contemporary

Stainless Steel | French hinge



Designed for those who need plenty of flexible space for their cold and frozen food storage, with a stylish stainless steel finish.

- ActiveSmart™ helps keep food fresher for longer
- Bottom freezer drawer
- Brushed metal handles

DIMENSIONS

Height	67 3/4 "
Width	31 1/8 "
Depth	27 3/8 "

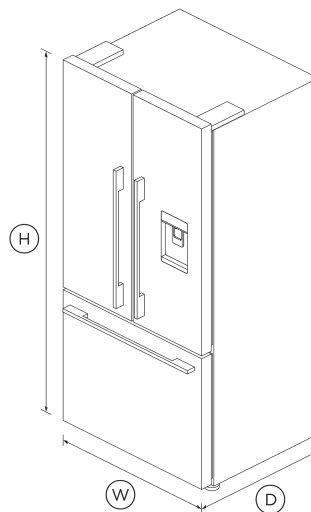

FEATURES & BENEFITS

Activesmart™ Foodcare

ActiveSmart™ Foodcare learns how you live. It's technology which understands how you use your refrigerator and adjusts temperature, airflow and humidity inside to help keep food fresher for longer.

Design Quality

Our refrigerators are designed and built using quality materials. We use real stainless steel on our refrigerators and solid glass for shelving.

WATER ON TAP

The slimline dispenser makes it easy to fill almost any sized jug or vessel with cool filtered water and doesn't take up any storage space in your refrigerator.

Clever Energy

Your refrigerator adapts to daily use by cooling and defrosting only when needed. This means your refrigerator uses the energy it needs without compromising on food care.

Ice Maker

Fresh ice is always available for you in a dedicated freezer bin. Simply turn it off to free up freezer space or during busy times, you can boost ice production by up to 30%.

Humidity Control

Your fruit and veges need different environments. The humidity control slides in each storage bin create a microclimate that helps keep food fresher for longer.

Easy Cleaning

No more permanent dirty marks with our EZKleen feature for stainless steel refrigerators. Anti-fingerprint coating means you simply wipe clean any marks. Spill-safe secure glass shelves easily capture any drips or leaks.

SPECIFICATIONS

Accessories (sold separately)

Handle kit Contemporary round, aluminium	25376
Water filter replacement	847200 - FWC3

Capacity

Total gross capacity	16.9 cu ft
Volume freezer	4.8 cu ft
Volume refrigerator	12.1 cu ft

Consumption

Energy rating	Energy star
Energy usage	448kWh/year
In-use energy carbon emissions estimate	55.2kgCO2e/year

Features

Adjustable door shelves	8
Adjustable glass shelves	3
Covered door shelves	2
Door alarm	•
Fruit and vegetable bins	2
LED lighting	•
Smart appliance US CA	•
SmartTouch control panel	•
Soft close doors	•
Stackable bottle holders	4
Ultra slim water dispenser	•
Water Filter	Part number 836848
Wi-Fi connectivity	•

Freezer Features

Automatic ice maker	•
Bottle chill	•
Fast freeze	•
Ice Boost	•

Performance

ActiveSmart™ Foodcare	•
Adaptive defrost	•
Frost free freezer	•
Humidity control system	•
Sabbath mode	•

Product dimensions

Depth	27 3/8 "
Height	67 3/4 "
Minimum air clearance at rear	1 3/16 "
Minimum air clearance each side	1 3/16 "
Width	31 1/8 "

Warranty

Parts and labor	2 years
Sealed system parts & labor	additional 3 years

SKU	26281
-----	-------

The product dimensions and specifications in this page apply to the specific product and model. Under our policy of continuous improvement, these dimensions and specifications may change at any time. You should therefore check with Fisher & Paykel's Customer Care Centre to ensure this page correctly describes the model currently available. © Fisher & Paykel Appliances Ltd 2020

Other product downloads available at fisherpaykel.com

- [↓ 2D-DWG Freestanding French Door Fridge Freezer](#)
- [↓ 2D-DXF Freestanding French Door Fridge Freezer](#)
- [↓ Data Sheet Freestanding French Door Fridge Freezer](#)
- [↓ Energy Label](#)
- [↓ Service & Warranty](#)
- [↓ Water Filter Replacement Instructions & Installation Guide EN](#)
- [↓ Installation Guide - Quick Reference EN](#)
- [↓ Guide d'installation - Instructions de Remplacement du Filtre à Eau FR](#)
- [↓ Installation Guide](#)
- [↓ Guide d'installation FR](#)
- [↓ User Guide](#)
- [↓ Guide d'utilisation FR](#)

Where applicable:

All appliances use energy, and energy usage typically generates carbon emissions. **Fisher & Paykel Appliances' In-use Energy Carbon Emissions Estimate** indicates carbon emissions from a product's in-use energy. This is calculated either annually or per cycle, using the product's market-specific energy label energy consumption data multiplied by the carbon emissions factor for energy in your country or region.

Our In-use Energy Carbon Emissions Estimate is designed to assist customers in making informed purchasing decisions when comparing different Fisher & Paykel products. For example, a heat pump dryer typically has a lower In-use Energy Carbon Emissions Estimate than a vented dryer.



A PEACE OF MIND SALE
24 Hours 7 Days a Week Customer Support

T 1.888.936.7872 W www.fisherpaykel.com