

Freestanding Refrigerator Freezer, 32", 17.5 cu ft, Ice & Water

Series 5 | Contemporary

Stainless Steel | Right Hinge



This stylish right hinge refrigerator comes in timeless stainless steel with concealed handles for a more streamlined look.

- Bottom freezer
- ActiveSmart™ helps keep food fresher for longer
- Ultra flat door conceals handles for streamlined look

DIMENSIONS

Height	67 3/4 "
Width	31 1/8 "
Depth	27 3/8 "

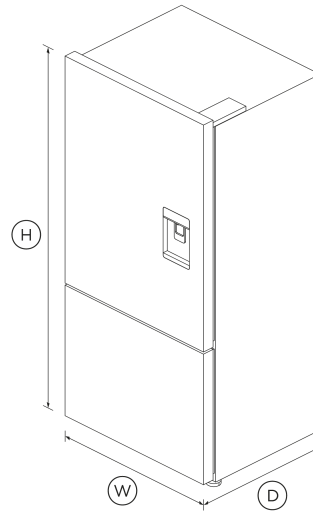

FEATURES & BENEFITS

ActiveSmart™ Foodcare

Every time you open your refrigerator, the temperature around your food changes. ActiveSmart™ foodcare adjusts airflow to create a stable temperature, helping your food stay fresher for longer.

Clever Energy

Your refrigerator adapts to daily use by cooling and defrosting only when needed. This means your refrigerator uses the energy it needs without compromising on food care.

Humidity Control

Your fruit and veges need different environments. The humidity control slides in each storage bin create a microclimate that helps keep food fresher for longer.

Easy Cleaning

No more permanent dirty marks with our EZKleen feature for stainless steel refrigerators. Anti-fingerprint coating means you simply wipe clean any marks. Spill-safe secure glass shelves easily capture any drips or leaks.

Ice Maker

Fresh ice is always available for you in a dedicated freezer bin. Simply turn it off to free up freezer space or during busy times, you can boost ice production by up to 30%.

Design Quality

Our refrigerators are designed and built using quality materials. We use real stainless steel on our refrigerators and solid glass for shelving.

Water On Tap

The slimline dispenser makes it easy to fill almost any sized jug or vessel with cool filtered water and doesn't take up any storage space in your refrigerator.

SPECIFICATIONS

Accessories (sold separately)

Water filter replacement	847200 - FWC3
--------------------------	---------------

Capacity

Total gross capacity	17.5 cu ft
Volume freezer	5.2 cu ft
Volume refrigerator	12.3 cu ft

Consumption

Energy usage	538kWh/year
In-use energy carbon emissions estimate	66.3kgCO2e/year

- Ice Boost •
- Large plastic bins •
- Slide Out Pastry Tray •

SKU 26288

Features

Adjustable door shelves	12
Adjustable glass shelves	4
Covered door shelves	2
Door alarm	•
Front levelling feet	•
Fruit and vegetable bins	2
Full extension runners	•
Full width door shelves	2
LED lighting	•
Rear rollers	•
Smart appliance US CA	•
SmartTouch control panel	•
Spill proof removable bins	•
Stackable bottle holders	2
Ultra slim water dispenser	•
Wi-Fi connectivity	•

Performance

- ActiveSmart™ Foodcare •
- Adaptive defrost •
- External water dispenser •
- Frost free •
- Inverter controlled compressor •
- Sabbath mode •

The product dimensions and specifications in this page apply to the specific product and model. Under our policy of continuous improvement, these dimensions and specifications may change at any time. You should therefore check with Fisher & Paykel's Customer Care Centre to ensure this page correctly describes the model currently available. © Fisher & Paykel Appliances Ltd 2020

Other product downloads available at fisherpaykel.com

- [↓](#) 2D-DWG Freestanding Refrigerator Freezer
- [↓](#) 2D-DXF Freestanding Refrigerator Freezer
- [↓](#) Data Sheet Freestanding Refrigerator Freezer
- [↓](#) Energy Label
- [↓](#) Service & Warranty
- [↓](#) Water Filter Replacement Instructions & Installation Guide EN
- [↓](#) Installation Guide - Quick Reference EN
- [↓](#) Installation Guide - Joiner Kit EN
- [↓](#) Guide d'installation - Instructions de Remplacement du Filtre à Eau FR
- [↓](#) Guide d'installation - kit de menuisier FR
- [↓](#) Installation Guide
- [↓](#) Guide d'installation FR
- [↓](#) User Guide
- [↓](#) Guide d'utilisation FR

Product dimensions

Depth	27 3/8 "
Height	67 3/4 "
Minimum air clearance at rear	1 3/16 "
Minimum air clearance each side	1 3/16 "
Minimum air clearance on top	2 "
Width	31 1/8 "

Variable Temp Compartment

- Bottle chill mode •

Freezer Features

Automatic ice maker	•
Bottle chill	•
Door alarm	•
Fast freeze	•
Freezer bins	2
Ice bin and scoop	•

Warranty

Parts and labor	2 years
Sealed system parts & labor	additional 3 years

Where applicable:

All appliances use energy, and energy usage typically generates carbon emissions. **Fisher & Paykel Appliances' In-use Energy Carbon Emissions Estimate** indicates carbon emissions from a product's in-use energy. This is calculated either annually or per cycle, using the product's market-specific energy label energy consumption data multiplied by the carbon emissions factor for energy in your country or region.

Our In-use Energy Carbon Emissions Estimate is designed to assist customers in making informed purchasing decisions when comparing different Fisher & Paykel products. For example, a heat pump dryer typically has a lower In-use Energy Carbon Emissions Estimate than a vented dryer.



A PEACE OF MIND SALE
24 Hours 7 Days a Week Customer Support
T 1.888.936.7872 W www.fisherpaykel.com