

8kg Series 7 Condensing Dryer, Auto-Sensing, Rack Dry

Series 7 | Condensing

White



With no need to vent moisture outside your condensing dryer can be incorporated into any laundry design, for a beautiful laundry.

- 11 drying cycles including Delicate, Easy Iron and Rack Dry
- Auto-sensing detects moisture levels to prevent under or over drying
- No need for external venting, allowing your dryer to be placed anywhere in your home

DIMENSIONS

Height	850 mm
Width	600 mm
Depth	650 mm

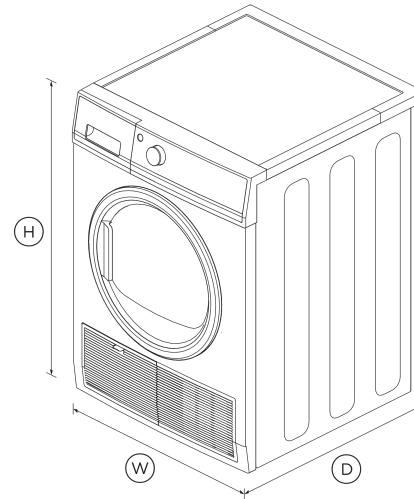

FEATURES & BENEFITS

Healthier Drying

Condensing technology drains water from the dryer into a tank. This reduces moisture and allergens released into your laundry, compared with a front venting dryer. A healthier choice for allergy sufferers.

Easy To Use

This dryer has a cycle to suit every type of load including Delicate, Heavy and Freshen. Select a cycle with the easy to use SmartTouch™ control dial.

Drying Rack

This model comes with a drying rack, perfect for those items that are too precious to tumble.

Cares For Clothes

Auto-sensing prevents over-drying by sensing moisture levels inside the drum and shutting off automatically. This helps clothes last for longer and reduces energy consumption.

Drum Light

A handy interior light turns on when you open the dryer door, providing improved visibility inside the drum.

Perfect Pair

Fisher & Paykel washing machines and dryers are designed to match and look stylish together in your laundry - they can be stacked to offer you more storage space.

SPECIFICATIONS

Capacity

Total capacity	8 kg
----------------	------

Dry Cycles

Air Dry	•
Delicate	•
Easy Iron	•
Everyday	•
Heavy	•
Number of cycles	11
Rack dry	•
Sheets	•
Time to dry 30	•
Time to dry 60	•

Time to dry 90 •

Height **850 mm**

Width **600 mm**

Features

- Clean condenser filter reminder •
- Clean door lint filter reminder •
- Drain hose **included**
- Drum light •
- Drying rack •
- Easy access lint filter •
- End of cycle signal •
- No external venting •
- Progress indicator •
- Removable water tank •
- SmartTouch™ control dial •
- Stainless steel drum •
- Time to go •
- Wrinkle free option •

Warranty

Parts and labour **2 years**

SKU 95126

The product dimensions and specifications in this page apply to the specific product and model. Under our policy of continuous improvement, these dimensions and specifications may change at any time. You should therefore check with Fisher & Paykel's Customer Care Centre to ensure this page correctly describes the model currently available. © Fisher & Paykel Appliances Ltd 2020

Other product downloads available at fisherpaykel.com

- [↓ Service & Warranty](#)
- [↓ Installation Guide](#)
- [↓ Installation Guide - Cavity Sizes](#)

Where applicable:

All appliances use energy, and energy usage typically generates carbon emissions. **Fisher & Paykel Appliances' In-use Energy Carbon Emissions Estimate** indicates carbon emissions from a product's in-use energy. This is calculated either annually or per cycle, using the product's market-specific energy label energy consumption data multiplied by the carbon emissions factor for energy in your country or region.

Our In-use Energy Carbon Emissions Estimate is designed to assist customers in making informed purchasing decisions when comparing different Fisher & Paykel products. For example, a heat pump dryer typically has a lower In-use Energy Carbon Emissions Estimate than a vented dryer.



A PEACE OF MIND SALE
24 Hours 7 Days a Week Customer Support
 T +65 6741 0777 W www.fisherpaykel.com

Performance

- Auto sensing •
- Condensing •
- Dryness settings **5**
- Reverse tumbling **Semi reverse tumbling**
- Temperature settings **4**
- Time dry **30, 60, 90 mins**

Product dimensions

Depth **650 mm**