

Electric Range 30" - Ceramic Radiant

Series 7 | Contemporary

Stainless Steel



A refined electric range with multiple oven functions for perfect cooking of anything from a large roast to baking bread and pastry.

- Electric radiant cooktop with four cook elements
- Nine oven functions including Roast, Aero™ Pastry with Pizza mode, and Rapid Proof for baking bread
- High-temperature self-cleaning function breaks down food residue for an easy clean

DIMENSIONS

Height	35 3/4 - 37 5/8 "
Width	29 7/8 "
Depth	25 1/4 "

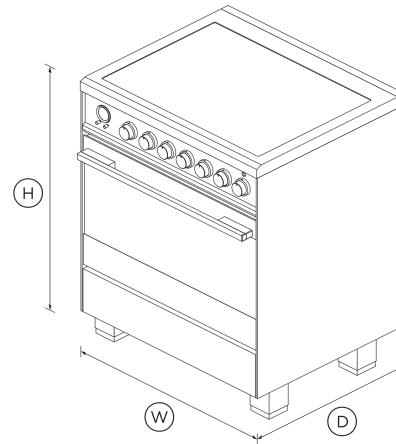

FEATURES & BENEFITS

Cooking Flexibility

Accurate, electronically-controlled oven heat, ensures a great result every time with 9 functions and pre-set temperatures including bake, grill, pastry bake with pizza mode and fan forced, for a variety of cooking styles.

A Modern Legacy

A refined, minimalist style with attention to the smallest details. High-performance cooking technology offers multiple cooking functions.

Quality And Durability

Every detail has been carefully crafted. The solid, perfectly balanced soft-close door, machined stainless dials and glowing halo dials all add up to an exceptional, premium range.

Large Capacity Oven

The generous 3.5 cu.ft total capacity oven gives you plenty of space to cook multiple dishes at once, with enough room to fit a 26 lb turkey.

Easy To Clean

Cleaning up spills is effortless. The flat ceramic cooktop is easily wiped after use, and the self-cleaning oven breaks down food residue at a very high temperature leaving a light ash that's easily removed with a damp cloth.

Even Heat

Accurate, electronically-controlled oven heat ensures a great result every time. Dishes on the top shelf turn out as perfectly as the ones on the bottom due to our AeroTech™ convection system that circulates air evenly throughout the entire oven.

SPECIFICATIONS

Accessories (included)

2-pc grill system (Broil pan and Grill rack)	•
Broil pan	•
Full extension telescopic shelves	2 sets (part 578776)

Accessories (sold separately)

Hob rear trim	3 1/8" (part 81656)
Kick strip, stainless steel (optional)	KICKOR30X1

Capacity	
Shelf positions	7
Total capacity	3.5 cu ft
Usable capacity	2.9 cu ft

Cleaning	
Acid resistant graphite enamel	•
Drop down broil element	•
Drop down grill element	•
Flat easy clean glass surface	•
Pyrolytic proof shelf runners	•
Pyrolytic self-clean	•
Removable oven door	•
Removable shelf runners	•

Controls	
Audio feedback	•
Automatic cooking/minute timer	•
Automatic pre-set temperatures	•
Celsius/Fahrenheit temperature	•
Electronic clock	•
High resolution display	•
Laser etched graphics	•
Precise electronic temperature control	•
Sabbath mode	•
Toughened fused glass graphics	•
Turned stainless steel clock buttons	•
Turned stainless steel dials with illuminated halos	•

Oven features	
AeroTech™ technology	•
Automatic rapid pre-heat	•
Concealed element	•
Electronic oven control	•
Full extension telescopic sliding shelves	•
Internal light	2 x 25W halogen (rear)
Soft open/close door	•
True convection	•
Turned stainless steel clock dial	•

Oven functions	
Aero™ Bake	•
Aero™ Pastry with Pizza mode	•
Number of functions	9
Rapid proof	•
Roast	•
True convection	•

Oven performance	
Broil power	4050 W
CoolTouch door	Triple glazed
Warming drawer power	220 W

Power Requirements	
Amperage	50 A
Supply frequency	60 Hz

Product Dimensions	
Depth	25 1/4 "
Height	35 3/4 - 37 5/8 "
Width	29 7/8 "

Rangetop Performance	
Number of cooking zones	4

Safety	
ADA compliant	•
Advanced cooling system	•
Anti-tilt bracket	•
Balanced oven door	•
Catalytic venting system	•
CoolTouch door	•
Full extension telescopic sliding shelves	•
Hi-light high speed ribbon elements	•
Individual hot surface indicators	•
Non-tip shelves	•
Spill containment	68.13 L
Spill containment	1/8 gallon

SKU 81721

The product dimensions and specifications in this page apply to the specific product and model. Under our policy of continuous improvement, these dimensions and specifications may change at any time. You should therefore check with Fisher & Paykel's Customer Care Centre to ensure this page correctly describes the model currently available. © Fisher & Paykel Appliances Ltd 2020



A PEACE OF MIND SALE
24 Hours 7 Days a Week Customer Support
T 1.888.936.7872 W www.fisherpaykel.com

Other product downloads available at fisherpaykel.com

- [↓](#) 2D-DWG Electric Range
- [↓](#) 2D-DXF Electric Range
- [↓](#) Data Sheet Electric Range
- [↓](#) Service & Warranty
- [↓](#) Installation Guide Freestanding Cooker EN
- [↓](#) Revit Electric Range
- [↓](#) Rhino Electric Range
- [↓](#) Sketchup Electric Range
- [↓](#) User Guide Freestanding Range EN

Where applicable:

All appliances use energy, and energy usage typically generates carbon emissions. **Fisher & Paykel Appliances' In-use Energy Carbon Emissions Estimate** indicates carbon emissions from a product's in-use energy. This is calculated either annually or per cycle, using the product's market-specific energy label energy consumption data multiplied by the carbon emissions factor for energy in your country or region.

Our In-use Energy Carbon Emissions Estimate is designed to assist customers in making informed purchasing decisions when comparing different Fisher & Paykel products. For example, a heat pump dryer typically has a lower In-use Energy Carbon Emissions Estimate than a vented dryer.