

Freestanding Quad Door Refrigerator Freezer, 36", 18.9 cu ft, Ice & Water

Series 7 | Contemporary

Stainless Steel | French hinge



With brilliant LED lighting and three independent compartments including a Variable Temperature Zone, for truly flexible storage.

- ActiveSmart™ technology helps keep food fresher for longer by constantly maintaining the ideal temperature.
- Door water dispenser and internal ice maker with boost function
- Variable Temperature Zone lets you change a compartment to Fridge, Chill, Soft Freeze or Freezer for optimal storage

- Spacious bottom freezer with full extension drawer gives easy access to frozen goods

DIMENSIONS

Height	70 1/2 "
Width	35 5/8 "
Depth	27 1/16 "

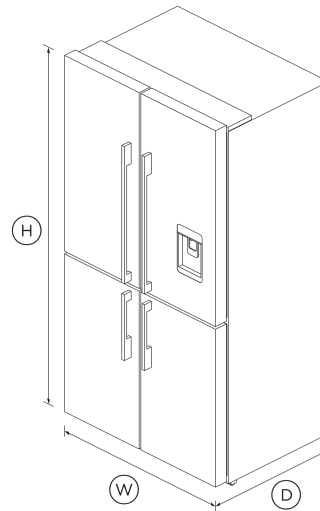

FEATURES & BENEFITS

VARIABLE TEMPERATURE ZONE

At the touch of a button, easily convert the lower right compartment to suit different food types, giving you storage flexibility for everyday needs as well as special occasions. Choose from Freezer, Soft Freeze, Chill and Fridge modes.

Flexible storage

Three large, independent compartments provide ample storage space. Easily adjustable cantilevered shelving in the refrigerator and full extension bins in the freezer provides maximum storage flexibility. A Variable Temperature Zone in the lower right compartment provides a true freezer temperature of -0.4°F.

Activesmart™ Foodcare

ActiveSmart™ Foodcare learns how you live. It is technology which understands how you use your fridge and adjusts temperature, airflow and humidity inside to help keep food fresher for longer.

ULTRA SLIM WATER DISPENSER

The slimline water dispenser is easy to use. The angled water delivery means that almost any size or shape of vessel can be filled. The slimline design maximizes storage space inside the door.

Ice maker

The internal ice maker delivers fresh ice to a dedicated freezer bin. Simply turn it off to free up freezer space or during busy times boost ice production by up to 30%.

DESIGN QUALITY

Our refrigerators are built using quality materials. We use real stainless steel, and solid glass for the interior shelving. Thoughtfully designed bins feature smooth, fully extendable telescopic runners for full access to storage space.

EASY ONE-TOUCH CONTROL PANEL

Control panels for the refrigerator and freezer are conveniently located inside their respective compartments, allowing you to view and modify the features and options to suit any occasion. The Variable Temperature Zone control is on the top of the compartment door so you can easily select your desired food mode or adjust manually.

SPECIFICATIONS

Accessories (sold separately)

Water filter replacement **847200 - FWC3**

Stackable bottle holders **4**
 Ultra slim water dispenser •
 Wi-Fi connectivity •

Minimum air clearance each side **1 3/16 "**
 Minimum air clearance on top **1 3/16 "**
 Width **35 5/8 "**

Capacity

Total gross capacity **19 cu ft**
 Volume freezer **3.45 cu ft**
 Volume refrigerator **12.1 cu ft**
 Volume variable temperature compartment **3.45 cu ft**

Freezer Features

Automatic ice maker •
 Bottle chill •
 Door alarm •
 Fast freeze •
 Full extension clear bins **3**
 Ice bin and scoop •
 Ice Boost •
 LED Lighting •

Warranty

Parts and labor **2 years**
 Sealed system parts & labor **additional 3 years**

Consumption

Energy usage **562kWh/year**
 In-use energy carbon emissions estimate **206.0kgCO2e/year**

SKU **26554**

The product dimensions and specifications in this page apply to the specific product and model. Under our policy of continuous improvement, these dimensions and specifications may change at any time. You should therefore check with Fisher & Paykel's Customer Care Centre to ensure this page correctly describes the model currently available. © Fisher & Paykel Appliances Ltd 2020

Features

Adjustable door shelves **8**
 Cantilevered glass shelves **4**
 cantileveredGlassShelves **4**
 Covered door shelves **2**
 Door alarm •
 Front levelling feet •
 Fruit and vegetable bins **2**
 Full extension runners •
 LED lighting •
 Rear rollers •
 Smart appliance US CA •
 SmartTouch control panel •

Performance

ActiveSmart™ Foodcare •
 Frost Free Freezer •
 Humidity control system •
 Internal replaceable water filter •
 Inverter controlled compressor •
 R600a refrigerant •
 Sabbath mode •
 Variable Temperature Compartment Performance •

Other product downloads available at fisherpaykel.com

- [↓](#) 2D-DWG Freestanding Quad Door Fridge Freezer
- [↓](#) 2D-DXF Freestanding Quad Door Fridge Freezer
- [↓](#) Data Sheet Freestanding Quad Door Fridge Freezer
- [↓](#) Energy Label Freestanding Quad Door Refrigerator Freezer
- [↓](#) Service & Warranty
- [↓](#) Water Filter Replacement Instructions & Installation Guide EN
- [↓](#) Guide d'installation - Instructions de Remplacement du Filtre à Eau FR
- [↓](#) Installation Guide EN
- [↓](#) User Guide

Product Dimensions

Depth **27 1/16 "**
 Height **70 1/2 "**
 Minimum air clearance at rear **1 3/16 "**

Where applicable:

All appliances use energy, and energy usage typically generates carbon emissions. **Fisher & Paykel Appliances' In-use Energy Carbon Emissions Estimate** indicates carbon emissions from a product's in-use energy. This is calculated either annually or per cycle, using the product's market-specific energy label energy consumption data multiplied by the carbon emissions factor for energy in your country or region.

Our In-use Energy Carbon Emissions Estimate is designed to assist customers in making informed purchasing decisions when comparing different Fisher & Paykel products. For example, a heat pump dryer typically has a lower In-use Energy Carbon Emissions Estimate than a vented dryer.

**A PEACE OF MIND SALE****24 Hours 7 Days a Week Customer Support**T 1.888.936.7872 W www.fisherpaykel.com