

# 90cm Series 7 Tilt Chimney Wall Cooker Hood

Series 7 | Contemporary

Stainless Steel and Glass



With a tilted black glass hood, this ventilation option saves on space while adding contemporary design to your kitchen.

- With four fan speeds, plus boost function, select the perfect extraction rate for your cooking
- Powerful maximum air movement 617m<sup>3</sup>/hr
- Dishwasher safe filters that are easy to remove and clean

## DIMENSIONS

Height	800-1140 mm
Width	900 mm
Depth	380 mm

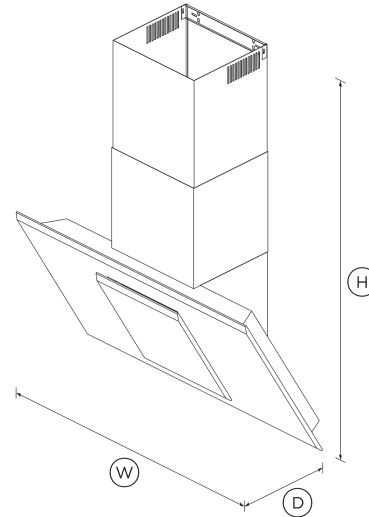

## FEATURES & BENEFITS

### Effective And Quiet

This cooker hood features four fan speeds, plus a boost function, providing powerful extraction to quickly remove odours and steam. As odours can linger in the kitchen well after cooking is finished, the timer keeps the rangehood working for up to 15 minutes before automatically turning off.

### Simple To Use

This Fisher & Paykel tilt cooker hood features a sleek and easy to use touch-control panel. Low energy, dimmable LED lights provide superb illumination over the entire cooking surface.

### Easy Cleaning

Designed for simple removal, the filters are easy to clean and dishwasher safe. The black glass finish just needs a quick wipe to keep clean. An alert reminds you when to clean the filter to ensure you get the best performance out of your cooker hood.

### Designed To Match

This wall chimney tilt cooker hood features sleek black glass and stainless steel styling which will complement any contemporary kitchen and is designed to match the rest of Fisher & Paykel's kitchen appliance family.

## SPECIFICATIONS

### Accessories (included)

Aluminium filter	791761
------------------	--------

### Accessories (sold separately)

Eave ducting kit	PD-RHK15OE
Light bulb	792556
Recirculation diverter	791820
Roof ducting kit	PD-RHK15OR
Side wall ducting kit	PD-RHK15OW

### Consumption

Energy rating	B
Energy usage	47kWh/year
In-use energy carbon emissions estimate	14.5kgCO <sub>2</sub> e/year

### Fan ratings

Maximum air movement	617 m <sup>3</sup> /hr
Maximum pressured air movement EN61591 at boost	617 m <sup>3</sup> /hr
Maximum sound rating	69 dB

**Installation and cleaning**

Air outlet size	150 mm
Dishwasher safe filters	1
Ducted	Top and back extraction
Recirculation	Optional - top extraction
Two piece height adjustable flue	•

**Performance**

Extraction type	Perimeter
Fan speeds	4
Filter type	Mesh with perimeter extraction
Number of filters	1

**Power requirements**

Lighting power	7 W
Motor power	130 W
Rated current	3 A
Supply frequency	50 Hz
Supply voltage	220-240 V
Total Power	130 W

**Product dimensions**

Depth	380 mm
Height	800-1140 mm
Width	900 mm

**Product information**

Control type	Capacitive touch
--------------	------------------

**Ventilation features**

Dimmable lights	•
Filter cleaning alert	•
Light type	LED
Timer function	•

**Warranty**

Parts and labour	5 years
------------------	---------

SKU	50124
-----	-------

The product dimensions and specifications in this page apply to the specific product and model. Under our policy of continuous improvement, these dimensions and specifications may change at any time. You should therefore check with Fisher & Paykel's Customer Care Centre to ensure this page correctly describes the model currently available. © Fisher & Paykel Appliances Ltd 2020

Other product downloads available at [fisherpaykel.com](http://fisherpaykel.com)

- [↓ 2D-DWG Wall Rangehood](#)
- [↓ 2D-DXF Wall Rangehood](#)
- [↓ Archicad Wall CookerHood](#)
- [↓ Data Sheet Wall Rangehood](#)
- [↓ Energy Label Wall Rangehood](#)
- [↓ Service & Warranty](#)
- [↓ Installation Guide](#)
- [↓ Product Information Sheet Wall Rangehood](#)
- [↓ Revit Wall CookerHood](#)
- [↓ Rhino Wall CookerHood](#)
- [↓ Sketchup Wall CookerHood](#)
- [↓ User Guide](#)

**Where applicable:**

All appliances use energy, and energy usage typically generates carbon emissions. **Fisher & Paykel Appliances' In-use Energy Carbon Emissions Estimate** indicates carbon emissions from a product's in-use energy. This is calculated either annually or per cycle, using the product's market-specific energy label energy consumption data multiplied by the carbon emissions factor for energy in your country or region.

Our In-use Energy Carbon Emissions Estimate is designed to assist customers in making informed purchasing decisions when comparing different Fisher & Paykel products. For example, a heat pump dryer typically has a lower In-use Energy Carbon Emissions Estimate than a vented dryer.



**A PEACE OF MIND SALE**  
**24 Hours 7 Days a Week Customer Support**  
 T 1800 625174 [Wwww.fisherpaykel.com](http://www.fisherpaykel.com)