

Front Loader Washing Machine, 10kg

Series 7 | Front Load

White



With plenty of room for large loads, and 13 wash cycles including Handwash, this front loader caters to every type of load.

- 13 wash cycles including Allergy, Easy Iron and Handwash
- Caters for busy lives with a 15 minute Super Quick cycle
- Add a Garment function allows you to add items mid cycle
- 4 star water and energy rating

DIMENSIONS

Height	850 mm
Width	600 mm
Depth	665 mm

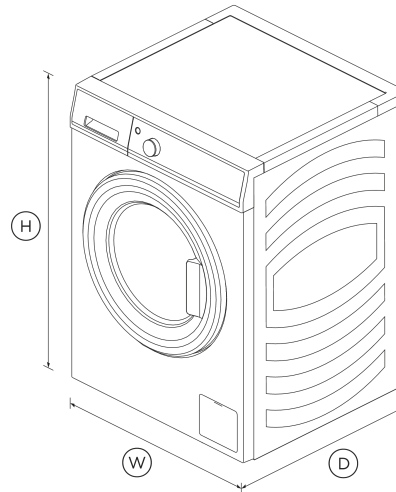

FEATURES & BENEFITS

Add A Garment

Add a Garment allows you to pause your wash cycle, add or remove any sized item, then carry on washing.

Smartdrive™ Technology

SmartDrive™ technology is a gentle, quiet, and efficient combination of smart electronics and a direct drive motor that senses the load, to deliver better fabric care.

Quiet Operation

Clever side paneling and engineered feet keep noise and vibration to a minimum - ideal for compact living spaces.

Easy Clean Dispenser

Clearly labelled compartments make it easy to see where to put washing powder and softener. It is cleverly shaped to minimise spills and is easy to remove and clean.

Water And Energy Efficient

With a 4 star water rating and 4 star energy rating, our 10kg washing machine handles large loads whilst keeping water and power usage to a minimum.

The Perfect Pair

This washing machine and our 8kg Condensing Dryer will clean, dry and beautifully care for clothes, while looking great together in your laundry.

SPECIFICATIONS

Accessories (sold separately)

Stacking kit Part 428159

Capacity

Capacity 10 kg

Features

- Add a garment (immediate door opening)
- Anti-fungal door gasket
- Auto out of balance correction
- Automatic water level
- Child/Keylock
- Delay start

Eco rinse	•
Extra rinse option	•
Flood protection	•
Hot and cold water inlets	•
Pre Wash	•
Progress indicator	•
SmartTouch™ control dial	•
Soil levels	3
Spin speeds	4
Stainless steel drum	•
Timed liquid detergent dispenser	•
Water supply	Hot & Cold
Water temperature controls	5
Wrinkle Free	•

Wash Cycles	
Allergy	•
Bulky	•
Cottons	•
Customise cycle	•
Delicate	•
Drum Clean	•
Easy Iron	•
Everyday	•
Handwash	•
Heavy	•
Number of wash cycles	13
Quick 30	•
Rinse	•
Spin	•
Super Quick	•

Where applicable:

All appliances use energy, and energy usage typically generates carbon emissions. **Fisher & Paykel Appliances' In-use Energy Carbon Emissions Estimate** indicates carbon emissions from a product's in-use energy. This is calculated either annually or per cycle, using the product's market-specific energy label energy consumption data multiplied by the carbon emissions factor for energy in your country or region.

Our In-use Energy Carbon Emissions Estimate is designed to assist customers in making informed purchasing decisions when comparing different Fisher & Paykel products. For example, a heat pump dryer typically has a lower In-use Energy Carbon Emissions Estimate than a vented dryer.



A PEACE OF MIND SALE
24 Hours 7 Days a Week Customer Support
 T +65 6741 0777 Wwww.fisherpaykel.com

SKU 93268

The product dimensions and specifications in this page apply to the specific product and model. Under our policy of continuous improvement, these dimensions and specifications may change at any time. You should therefore check with Fisher & Paykel's Customer Care Centre to ensure this page correctly describes the model currently available. © Fisher & Paykel Appliances Ltd 2020

Other product downloads available at [fisherpaykel.com](https://www.fisherpaykel.com)

[↓](#) Service & Warranty

Performance

Maximum spin speed	1200 rpm
Number of spin speeds	4
SmartDrive™ technology	•
Vortex wash	•

Product dimensions

Depth	665 mm
Height	850 mm
Width	600 mm

Warranty

Parts only SmartDrive™ motor	10 years
------------------------------	----------