

569L Series 7 French Door Refrigerator Freezer, Ice

Series 7 | Contemporary

Stainless Steel | French hinge



Our largest capacity French Door model has intuitive, flexible storage space, with a stylish stainless steel finish.

- ActiveSmart™ technology helps keep food fresher for longer by constantly maintaining the ideal temperature.
- Spacious bottom freezer with full extension drawer gives easy access to frozen goods.
- Internal ice maker with boost feature for busy times

DIMENSIONS

| | |
|--------|---------|
| Height | 1790 mm |
| Width | 900 mm |
| Depth | 695 mm |

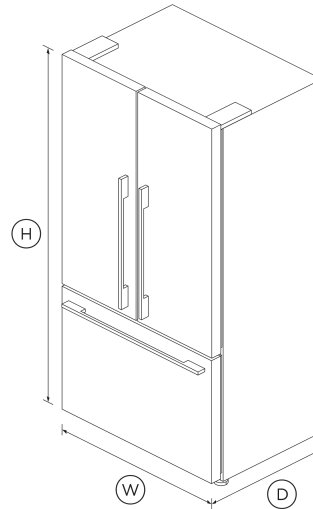

FEATURES & BENEFITS

Simple storage

This refrigerator is designed to make it simple for you to store, access and remove food. Storage bins give you full access inside when they're pulled open and can be easily removed to clean. Our flexible shelving also gives you more storage options.

Ice maker

Fresh ice is always available for you in a dedicated freezer bin. Simply turn it off to free up freezer space, or during busy times you can boost ice production by up to 30%.

Easy cleaning

No more permanent dirty marks with our EZKleen feature for stainless steel fridges. Anti-fingerprint coating means you simply wipe clean any marks. Spill-safe secure glass shelves easily capture any drips or leaks.

CLEVER ENERGY

Your refrigerator adapts to daily use by cooling and defrosting only when needed. This means it uses the energy it needs without compromising on food care.

Complementary Design

With their premium handle styling and stainless steel finish, our refrigerators are designed to match the rest of Fisher & Paykel's kitchen appliance family.

Humidity Control

Your fruit and veges need different environments. The humidity control slides in each storage bin create a microclimate that helps keep food fresher for longer.

SPECIFICATIONS

Accessories (sold separately)

| | |
|--------------------------|---------------|
| Water filter replacement | 847200 - FWC3 |
|--------------------------|---------------|

Capacity

| | |
|---------------------|-------|
| Total net volume | 569L |
| Volume freezer | 152 L |
| Volume refrigerator | 417 L |

Consumption

| | |
|---------------|---|
| Energy rating | E |
|---------------|---|

| | |
|---|------------------------|
| Energy usage | 297kWh/year |
| In-use energy carbon emissions estimate | 91.7kgCO2e/year |

| | |
|--------------|---|
| Ice Boost | • |
| LED Lighting | • |

| | |
|-------------------|---|
| Bottle chill mode | • |
|-------------------|---|

Controls

| | |
|----------------|---|
| Interior light | • |
|----------------|---|

Performance

| | |
|--------------------------------|---------------|
| ActiveSmart™ Foodcare | • |
| Adaptive defrost | • |
| Frost free | • |
| Frost free freezer | • |
| Humidity control system | • |
| Inverter controlled compressor | • |
| Noise emissions | 42 dBA |
| Noise emissions class | D |
| R600a refrigerant | • |
| Sabbath mode | • |

Warranty

| | |
|--------------------------|----------------|
| Parts and labour | 5 years |
| Sealed system parts only | 5 years |

Features

| | |
|----------------------------|---------------|
| Adjustable door shelves | 6 |
| Adjustable glass shelves | 3 |
| Covered door shelves | 2 |
| Deli storage bins | 2 |
| Door alarm | • |
| Front levelling feet | • |
| Fruit and vegetable bins | 2 |
| Full extension runners | • |
| LED lighting | • |
| Smart appliance | • |
| SmartTouch control panel | • |
| Spill proof removable bins | • |
| Stackable bottle holders | 4 |
| Water Filter | 836848 |

Power requirements

| | |
|----------------|--------------------|
| Supply voltage | 220 - 240 V |
|----------------|--------------------|

| | |
|-----|-------|
| SKU | 26686 |
|-----|-------|

The product dimensions and specifications in this page apply to the specific product and model. Under our policy of continuous improvement, these dimensions and specifications may change at any time. You should therefore check with Fisher & Paykel's Customer Care Centre to ensure this page correctly describes the model currently available. © Fisher & Paykel Appliances Ltd 2020

Other product downloads available at fisherpaykel.com

- [↓ Declaration of Conformity Refrigeration with WiFi Capability](#)
- [↓ Energy Label Freestanding French Door Refrigerator Freezer](#)
- [↓ Service & Warranty](#)
- [↓ Water Filter Replacement Instructions & Installation Guide EN](#)
- [↓ Installation Guide](#)
- [↓ Product Fiche](#)
- [↓ Product Information Sheet Freestanding Fridge Freezer](#)
- [↓ User Guide](#)

Freezer Features

| | |
|---------------------|---|
| Automatic ice maker | • |
| Bottle chill | • |
| Door alarm | • |
| Fast freeze | • |
| Ice bin and scoop | • |

Product dimensions

| | |
|-----------------------------------|----------------|
| Depth | 695 mm |
| Depth (including handles) | 730 mm |
| Height | 1790 mm |
| Height to top of cabinet | 1790 mm |
| Minimum air clearance - each side | 20 mm |
| Minimum air clearance - on top | 50 mm |
| Width | 900 mm |

Where applicable:

Variable Temp Compartment

All appliances use energy, and energy usage typically generates carbon emissions. **Fisher & Paykel Appliances' In-use Energy Carbon Emissions Estimate** indicates carbon emissions from a product's in-use energy. This is calculated either annually or per cycle, using the product's market-specific energy label energy consumption data multiplied by the carbon emissions factor for energy in your country or region.

Our In-use Energy Carbon Emissions Estimate is designed to assist customers in making informed purchasing decisions when comparing different Fisher & Paykel products. For example, a heat pump dryer typically has a lower In-use Energy Carbon Emissions Estimate than a vented dryer.



A PEACE OF MIND SALE
24 Hours 7 Days a Week Customer Support
T 1800 625174 W www.fisherpaykel.com