

Freestanding Range Cooker, Dual Fuel, 90cm, 5 Burners

Series 7 | Classic

Black



Get the best of both worlds with dual fuel. A gas hob with wok burner is paired with a nine-function convection oven.

- Five burner gas hob, with precise heat control
- Convection oven with 140L total capacity and nine oven functions including Pastry Bake with pizza mode and rapid proof for making bread
- Non-tip full-extension shelves for safe removal of hot dishes

DIMENSIONS

Height	898 - 946 mm
Width	897 mm
Depth	600 mm

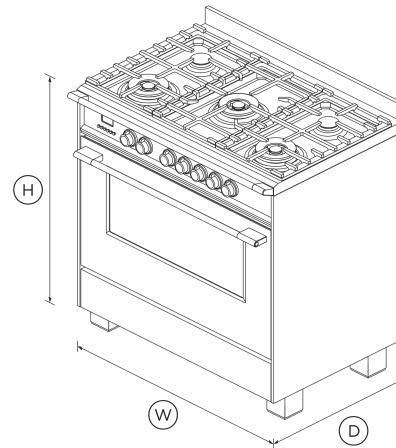

FEATURES & BENEFITS

Multi-Shelf Cooking

Our AeroTech™ system circulates air evenly throughout the entire oven so dishes on the top shelf turn out just as perfectly as food cooking on the bottom shelf.

Quality And Durability

Every detail has been carefully crafted. The solid, perfectly balanced soft-close door, durable hob trivets and glowing halo dials all add up to an exceptional, premium range.

Burner Power & Control

Instant and immediate control from the highest to the gentlest heat. The finely tuned hob controls let you sear, stir fry or simmer a delicate sauce to perfection.

Large Capacity Oven

The generous 140L total capacity oven gives you plenty of space to cook multiple dishes at once.

Easy To Clean

Your hob simply needs a quick wipe to keep it looking good as new for years to come, as the gas hob is made from a single piece of stainless steel that contains spills. The oven door, its inner pane of glass and runners can also be removed for easy cleaning.

Even Heat

Accurate, electronically-controlled oven heat ensures a great result every time.

SPECIFICATIONS

Accessories (included)

Chromed shelf runners	1 set
Flat wire shelf	1
Full extension sliding shelves	1 set (part 578744)
Full extension telescopic shelves	1 set (part 578744)
Grill rack	true
Roasting dish	1
Small pot support	1 (part 533981 cast)
Step down wire shelf	•

Accessories (sold separately)

Kick strip, stainless steel (optional)	KICKOR90B1	Energy usage	1.46kWh/cycle	Oven functions	
<hr/>		<hr/>		Bake	•
Burner ratings		Controls		Classic bake	•
Dual wok burner inner/outer (LPG)	0.3 - 4.5kW	Audio feedback	•	Energy slow cook	•
Dual wok burner inner/outer (natural gas)	0.4 - 4.5kW	Automatic cooking/minute timer	•	Fan bake	•
Maximum burner power	4.5kW	Automatic pre-set temperatures	•	Fan forced	•
Semi-rapid burner (LPG)	1.2kW	Celsius/Fahrenheit temperature	•	fanGrill	•
Semi-rapid burner (natural gas)	1.75kW	Electronic clock	•	Grill	•
Total cooktop power	14.9kW	Laser etched graphics	•	Number of functions	9
Triple ring wok burner (LPG) x2	4.0kW	Precise electronic temperature control	•	Pastry Bake with Pizza mode	•
Triple ring wok burner (natural gas) x2	4.0kW	Sabbath mode	•	Rapid proof	•
<hr/>		Turned stainless steel clock buttons	•	Roast	•
Capacity		<hr/>		True convection	•
Shelf positions	6	Installation Dimensions		<hr/>	
Shelf positions (main oven)	6	Installation cutout dimensions (Depth)	600 mm	Oven performance	
Total capacity	140 L	Installation cutout dimensions (Width)	900 mm	CoolTouch door	Quadruple glazed
Usable capacity	120 L	<hr/>		<hr/>	
Usable capacity (main oven)	120 L	Oven features		Power requirements	
<hr/>		AeroTech™ technology	•	Amperage	22 A
Cleaning		Automatic rapid pre-heat	•	Supply frequency	50 Hz
Acid resistant graphite enamel	•	Bright chromed, cast zinc dials with illuminated halos	•	<hr/>	
Drop down grill element	•	Electronic oven control	•	Product dimensions	
Removable oven door	•	Full extension telescopic sliding shelves	•	Depth	600 mm
Removable oven door inner glass	•	Internal light	4 x 25W halogen (2 side & 2 top)	Height	898 - 946 mm
Removable shelf runners	•	Soft open/close door	•	Width	897 mm
<hr/>		Storage drawer	•	<hr/>	
Consumption		Twin cavity fans	•	Rangetop features	
<hr/>		<hr/>		<hr/>	

Hob rail	•
Hob rear trim	60 mm
LPG / Natural Gas compatible	•
Sealed range top	•

The product dimensions and specifications in this page apply to the specific product and model. Under our policy of continuous improvement, these dimensions and specifications may change at any time. You should therefore check with Fisher & Paykel's Customer Care Centre to ensure this page correctly describes the model currently available. © Fisher & Paykel Appliances Ltd 2020



A PEACE OF MIND SALE
24 Hours 7 Days a Week Customer Support
 T 08000 886 605 Wwww.fisherpaykel.com

Rangetop Performance

Number of burners	5
-------------------	----------

Other product downloads available at fisherpaykel.com

- [↓ Declaration of Conformity](#)
- [↓ Energy Label Dual Fuel Cooker](#)
- [↓ Energy Rating](#)
- [↓ Service & Warranty](#)
- [↓ Installation Guide](#)
- [↓ Installation Guide - Kick Strip](#)
- [↓ Product Information Sheet](#)
- [↓ Product Fiche](#)
- [↓ User Guide Dual Fuel Cooker](#)

Safety

Advanced cooling system	•
Anti-tilt bracket	•
Balanced oven door	•
CoolTouch door	•
Flame failure system	•
Full extension telescopic shelves	1 set (part 578744)
Full extension telescopic sliding shelves	•
Non-tip shelves	•
Spill containment	26 L

Where applicable:

All appliances use energy, and energy usage typically generates carbon emissions. **Fisher & Paykel Appliances' In-use Energy Carbon Emissions Estimate** indicates carbon emissions from a product's in-use energy. This is calculated either annually or per cycle, using the product's market-specific energy label energy consumption data multiplied by the carbon emissions factor for energy in your country or region.

Our In-use Energy Carbon Emissions Estimate is designed to assist customers in making informed purchasing decisions when comparing different Fisher & Paykel products. For example, a heat pump dryer typically has a lower In-use Energy Carbon Emissions Estimate than a vented dryer.

Warranty

Parts and labour	5 years
------------------	----------------

SKU	81697
-----	-------