

# Freestanding French Door Refrigerator Freezer, 32", 16.8 cu ft, Ice & Water

Series 7 | Contemporary

Stainless Steel | French hinge



Designed for those who need plenty of flexible space. Counter-depth design, with a stylish stainless steel finish for a seamless look.

- ActiveSmart™ technology helps keep food fresher for longer by constantly maintaining the ideal temperature.
- Door water dispenser and internal ice maker with boost function
- Spacious bottom freezer with easy-slide internal drawers to separate storage

- With SmartTouch control panel for ease of use

## DIMENSIONS

Height	70 1/2 "
Width	31 1/8 "
Depth	27 1/16 "

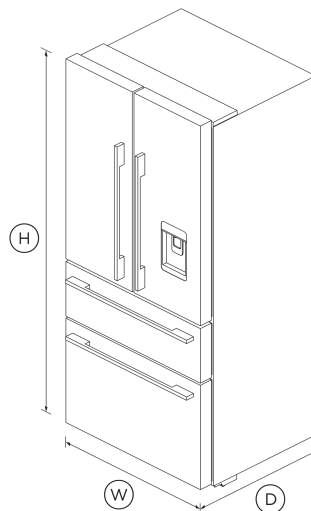

## FEATURES & BENEFITS

### Activesmart™ Foodcare

ActiveSmart™ Foodcare learns how you live. It is technology which understands how you use your refrigerator and adjusts temperature, airflow and humidity inside to help keep food fresher for longer.

### Easy Slide Drawers

With two independent freezer drawers and adjustable internal shelving and storage options, this refrigerator can be configured to suit your constantly changing needs.

### Ultra Slim Water Dispenser

The slimline water dispenser is easy to use. The angled water delivery means that almost any size or shape of vessel can be filled, while taking up no storage space in the door.

### Ice Maker

The internal ice maker delivers fresh ice to a dedicated freezer bin. Simply turn it off to free up freezer space or during busy times boost ice production by up to 30%.

### Design Quality

Our refrigerators are designed and built using quality materials. We use real stainless steel, brilliant LED lighting, and solid glass for the interior shelving.

### Easy To Organize

There are multiple storage options for you to choose from. Different sized adjustable shelves and door storage give you plenty of room to stack and pack all your groceries. Full extension runners make it easy to remove storage bins and clean them out.

## SPECIFICATIONS

### Accessories (sold separately)

Water filter replacement **847201 - FWC4**

### Capacity

Total gross capacity	<b>16.8 cu ft</b>
Volume freezer	<b>6.2 cu ft</b>
Volume refrigerator	<b>10.6 cu ft</b>

**Features**

Adjustable door shelves	8
Cantilevered glass shelves	4
cantileveredGlassShelves	4
Covered door shelves	2
Door alarm	•
Front levelling feet	•
Fruit and vegetable bins	2
Full extension runners	•
LED lighting	•
Rear rollers	•
SmartTouch control panel	•
Stackable bottle holders	4
Ultra slim water dispenser	•

**Freezer Features**

Automatic ice maker	•
Bottle chill	•
Door alarm	•
Fast freeze	•
Ice bin and scoop	•
Ice Boost	•
LED Lighting	•

**Performance**

ActiveSmart™ Foodcare	•
Frost Free Freezer	•
Humidity control system	•
Internal replacable water filter	•

Inverter controlled compressor	•
R600a refrigerant	•
Sabbath mode	•

**Product Dimensions**

Depth	27 1/16 "
Height	70 1/2 "
Minimum air clearance at rear	1 3/16 "
Minimum air clearance each side	1 3/16 "
Minimum air clearance on top	1 3/16 "
Width	31 1/8 "

**Warranty**

Parts and labor	2 years
Sealed system parts & labor	additional 3 years

SKU 24885

The product dimensions and specifications in this page apply to the specific product and model. Under our policy of continuous improvement, these dimensions and specifications may change at any time. You should therefore check with Fisher & Paykel's Customer Care Centre to ensure this page correctly describes the model currently available. © Fisher & Paykel Appliances Ltd 2020

**Other product downloads available at fisherpaykel.com**

[↓](#) 2D-DWG Freestanding French Door Fridge Freezer

- [↓](#) 2D-DXF Freestanding French Door Fridge Freezer
- [↓](#) Data Sheet Freestanding French Door Fridge Freezer
- [↓](#) Energy Label Freestanding Quad Door Refrigerator Freezer
- [↓](#) Service & Warranty
- [↓](#) Water Filter Replacement Instructions & Installation Guide EN
- [↓](#) Guide d'installation - Instructions de Remplacement du Filtre à Eau FR
- [↓](#) Installation Guide EN
- [↓](#) User Guide
- [↓](#) User Guide

**Where applicable:**

All appliances use energy, and energy usage typically generates carbon emissions. **Fisher & Paykel Appliances' In-use Energy Carbon Emissions Estimate** indicates carbon emissions from a product's in-use energy. This is calculated either annually or per cycle, using the product's market-specific energy label energy consumption data multiplied by the carbon emissions factor for energy in your country or region.

Our In-use Energy Carbon Emissions Estimate is designed to assist customers in making informed purchasing decisions when comparing different Fisher & Paykel products. For example, a heat pump dryer typically has a lower In-use Energy Carbon Emissions Estimate than a vented dryer.



**A PEACE OF MIND SALE**  
**24 Hours 7 Days a Week Customer Support**  
 T 1.888.936.7872 [Wwww.fisherpaykel.com](http://www.fisherpaykel.com)