

# 90cm Series 5 Contemporary Oven, 9 Function

Series 5 | Contemporary

Stainless Steel



With contemporary styling and clean lines in glass and steel, this built-in oven complements the style and elegance of any modern kitchen.

- One of the largest built-in ovens on the market providing 100L total capacity
- Nine functions including Pastry Bake, Roast and Fan Forced

- Features AeroTech - a technology that circulates heat evenly, ideal for multi shelf cooking

## DIMENSIONS

|        |        |
|--------|--------|
| Height | 478 mm |
| Width  | 895 mm |
| Depth  | 564 mm |

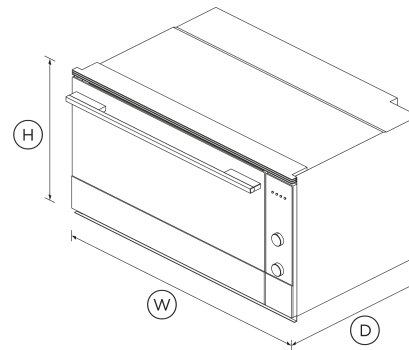

## FEATURES & BENEFITS

### Cooking Flexibility

This built-in oven has nine functions with pre-set temperatures, including Bake, Pastry Bake and Fan Forced, allowing you to use a variety of cooking styles.

### Sized To Suit

Designed for multi-shelf cooking, this is one of the largest built-in ovens on the market providing 100L total capacity. The wide cavity allows for both side by side and multi-shelf cooking.

### Designed To Match

With their premium handle styling and stainless steel finish, our built-in ovens are designed to match the rest of Fisher & Paykel's kitchen appliance family.

### Pre-Set Oven Functions

Oven functions are pre-set at the touch of a dial and brilliant lighting combined with a large viewing window reduce the need to open the oven door, providing perfect cooking results and improving energy efficiency.

### Safe And Sound

The CoolTouch door with triple glazing and cooling system is safe to touch from the outside, protecting your hands and the surrounding cabinetry.

### Perfect Results

This built-in oven features AeroTech - a technology that circulates heat evenly throughout the entire internal cavity to eliminate cold spots and ensure perfect, even results when cooking on multiple shelves.

## SPECIFICATIONS

### Accessories (included)

|                      |                       |
|----------------------|-----------------------|
| Grill rack           | 1 set                 |
| Roasting dish        | 1                     |
| Rotisserie set       | Optional (part 81942) |
| Step down wire shelf | 1                     |

|                 |       |
|-----------------|-------|
| <b>Capacity</b> |       |
| Shelf positions | 4     |
| Total capacity  | 100 L |
| Usable capacity | 85 L  |

|                     |   |
|---------------------|---|
| Number of functions | 9 |
| Pastry Bake         | • |
| Roast               | • |
| Rotisserie          | • |
| Warm                | • |

The product dimensions and specifications in this page apply to the specific product and model. Under our policy of continuous improvement, these dimensions and specifications may change at any time. You should therefore check with Fisher & Paykel's Customer Care Centre to ensure this page correctly describes the model currently available. © Fisher & Paykel Appliances Ltd 2020

|                                 |   |
|---------------------------------|---|
| <b>Cleaning</b>                 |   |
| Acid resistant graphite enamel  | • |
| Drop down grill element         | • |
| Removable oven door             | • |
| Removable oven door inner glass | • |
| Removable shelf runners         | • |

|                          |        |
|--------------------------|--------|
| <b>Performance</b>       |        |
| AeroTech™ technology     | •      |
| Automatic rapid pre-heat | •      |
| Grill power              | 3600 W |

**Other product downloads available at [fisherpaykel.com](https://fisherpaykel.com)**

- [↓ User Guide Built-in Oven](#)
- [↓ Service & Warranty](#)
- [↓ Installation Guide](#)
- [↓ User Guide](#)

|  |   |
|--|---|
| <b>Controls</b>  |   |
| Audio feedback   | • |
| Automatic cooking/minute timer                                   | • |
| Automatic pre-set temperatures                                   | • |
| Celsius/Fahrenheit temperature                                   | • |
| Electronic clock   | • |
| Electronic oven control  | • |
| Turned stainless capacitive touch buttons with illuminated halos | • |

|                           |         |
|---------------------------|---------|
| <b>Power requirements</b> |         |
| Amperage                  | 20.56 A |

**Where applicable:**

All appliances use energy, and energy usage typically generates carbon emissions. **Fisher & Paykel Appliances' In-use Energy Carbon Emissions Estimate** indicates carbon emissions from a product's in-use energy. This is calculated either annually or per cycle, using the product's market-specific energy label energy consumption data multiplied by the carbon emissions factor for energy in your country or region.

Our In-use Energy Carbon Emissions Estimate is designed to assist customers in making informed purchasing decisions when comparing different Fisher & Paykel products. For example, a heat pump dryer typically has a lower In-use Energy Carbon Emissions Estimate than a vented dryer.

|                  |   |
|------------------|---|
| <b>Functions</b> |   |
| Bake             | • |
| Fan bake         | • |
| Fan forced       | • |
| Fan grill        | • |
| Grill            | • |

|                           |        |
|---------------------------|--------|
| <b>Product dimensions</b> |        |
| Depth                     | 564 mm |
| Height                    | 478 mm |
| Width                     | 895 mm |

|                        |   |
|------------------------|---|
| <b>Safety</b>          |   |
| Balanced oven door     | • |
| Control panel key lock | • |
| CoolTouch door         | • |
| Non-tip shelves        | • |

|     |       |
|-----|-------|
| SKU | 81941 |
|-----|-------|



**A PEACE OF MIND SALE**  
 24 Hours 7 Days a Week Customer Support  
 T 1300 650 590 W [www.fisherpaykel.com](https://www.fisherpaykel.com)