

Dual Fuel Range, 48", 8 Burners, Self-cleaning, LPG

Series 9 | Professional

Stainless Steel | LPG



With intuitive touchscreen and specialized cooking functions across two ovens, this range is a stand-out addition to your kitchen.

- Guided cooking using your touchscreen makes it simple to cook by food, function or recipe.
- Top burner heat of 19,000 BTU, for seriously fast boiling
- 6.9 cu ft total oven capacity across two oven cavities
- Beautiful LED halo-illuminated dials provide information at a glance

DIMENSIONS

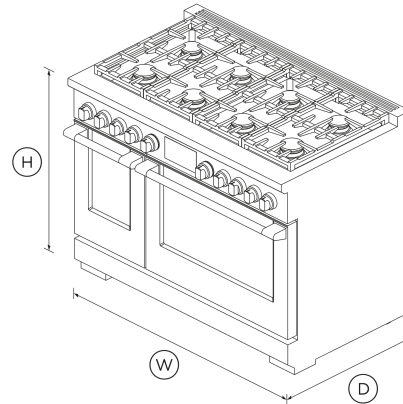

FEATURES & BENEFITS

Cook With Confidence

Our touchscreen interface provides an intuitive guided cooking experience that helps deliver perfect results, whether you've been cooking all your life or just starting out. Cook with a favorite method, a hero ingredient, or a go-to cooking function or recipe. The screen tilts for improved ergonomics and optimal visibility while cooking.

Generous Capacity

Two independently operating cavities provide a large total capacity of 4.8 cu. ft. in the main cavity and 2.1 cu. ft. in the secondary. That's enough room for a 32 lb turkey in one oven, and your sides in the other.

Cooking Flexibility

No matter what you're cooking, you've got the right heat to get perfect results. Each of the 15 oven functions in the main cavity and 11 in the secondary have been extensively researched and carefully designed to cater to a broad range of dishes and cooking styles. The handy food probe helps you monitor your progress.

Cooktop Power

Sealed dual flow burners deliver cooktop power up to 19,000 BTU for seriously fast boiling, and precise 140°F full surface, low temperature cooking with the gentlest of flames.

Design Quality

This range has craftsmanship in every detail, with real stainless steel, cast-iron grates, and beautifully weighted, halo illuminated dials. Each cavity features incandescent lights and full extension telescopic racks. From the robust legs to the powerful cooktop, this Range is built to last.

Easy To Clean

The oven features a self-cleaning function and self-clean proof side racks, which don't need to be removed when using this function.

SPECIFICATIONS

Burner ratings

Maximum burner power	19000 BTU
Power back centre	13000BTU
Power back centre (2)	13000BTU
Power back left	13000BTU
Power back right	13000BTU
Power front centre	15000BTU
Power front centre (2)	15000BTU
Power front left	19000BTU
Power front right	19000BTU

Total cooktop power **120000 BTU**

Gas Requirements

Fitting and pipe **½ NPT, min. ⅝" flex line**

Supply Pressure (LPG) **11" to 14" W.C**

SKU **81897**

The product dimensions and specifications in this page apply to the specific product and model. Under our policy of continuous improvement, these dimensions and specifications may change at any time. You should therefore check with Fisher & Paykel's Customer Care Centre to ensure this page correctly describes the model currently available. © Fisher & Paykel Appliances Ltd 2020

Other product downloads available at fisherpaykel.com

- [↓ 2D-DWG Dual Fuel Range](#)
- [↓ 2D-DXF Dual Fuel Range](#)
- [↓ 2D-DWG Dual Fuel Range with Backguard BGRV2-1248](#)
- [↓ 2D-DWG Dual Fuel Range with Backguard BGRV2-3048](#)
- [↓ 2D-DWG Dual Fuel Range with Backguard BGRV2-3048H and Angled Trim](#)
- [↓ 2D-DXF Dual Fuel Range with Backguard BGRV2-1248](#)
- [↓ 2D-DXF Dual Fuel Range with Backguard BGRV2-3048](#)
- [↓ 2D-DXF Dual Fuel Range with Backguard BGRV2-3048H and Angled Trim](#)
- [↓ ArchiCAD Dual Fuel Range](#)
- [↓ Data Sheet Dual Fuel Range with Backguard BGRV2-1248](#)
- [↓ Data Sheet Dual Fuel Range with Backguard BGRV2-3048](#)

- [↓ Data Sheet Dual Fuel Range with Backguard BGRV2-3048H and Angled Trim](#)
- [↓ Data Sheet Dual Fuel Range](#)
- [↓ Service & Warranty](#)
- [↓ Installation Guide EN](#)
- [↓ Guide d'installation FR](#)
- [↓ Planning Guide Professional Style Dial/Handle Accessories](#)
- [↓ Revit Dual Fuel Range](#)
- [↓ Rhino Dual Fuel Range](#)
- [↓ Sketchup Dual Fuel Range](#)
- [↓ Specification Guide Dual Fuel Range](#)
- [↓ User Guide EN](#)

Where applicable:

All appliances use energy, and energy usage typically generates carbon emissions. **Fisher & Paykel Appliances' In-use Energy Carbon Emissions Estimate** indicates carbon emissions from a product's in-use energy. This is calculated either annually or per cycle, using the product's market-specific energy label energy consumption data multiplied by the carbon emissions factor for energy in your country or region.

Our In-use Energy Carbon Emissions Estimate is designed to assist customers in making informed purchasing decisions when comparing different Fisher & Paykel products. For example, a heat pump dryer typically has a lower In-use Energy Carbon Emissions Estimate than a vented dryer.



A PEACE OF MIND SALE
24 Hours 7 Days a Week Customer Support
 T 1.888.936.7872 W www.fisherpaykel.com