

Integrated Rangehood, 90cm with External Motor

Series 7 | Integrated

Stainless Steel and Glass



This integrated insert rangehood has an externally installed inline motor to deliver near silent yet powerful extraction of steam, grease and cooking odours.

- With three fan speeds plus a boost function, select the perfect extraction rate for your cooking
- External motor delivers near silent operation in the kitchen
- Powerful maximum air movement of 1200m³/hr
- Wi-Fi enabled for notifications through the SmartHQ™ app

DIMENSIONS

Height	316 mm
Width	830 mm
Depth	280 mm

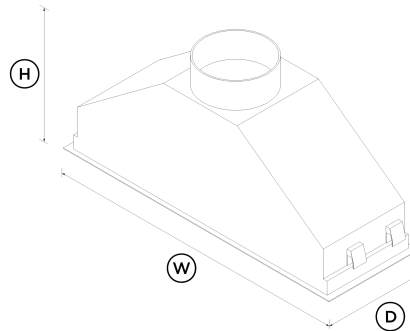

FEATURES & BENEFITS

Near Silent Extraction

The powerful external motor is installed outside the home to deliver near silent extraction of cooking odours and steam from the kitchen.

Seamless Integration

This rangehood can be built into your cabinetry for a seamless look. A black glass control panel and stainless steel finish are designed to match the rest of Fisher & Paykel's kitchen appliance family.

Effective Extraction

This rangehood features three fan speeds plus boost function, providing powerful extraction to quickly remove odours and steam. As odours can linger in the kitchen well after cooking is finished, the timer keeps the rangehood working for up to 15 minutes before automatically turning off.

Full Surface Lighting

Energy-efficient, dimmable LED lights provide superb illumination over the entire cooking surface.

Easy Cleaning

Designed for simple removal, the filters are easy to clean and dishwasher safe, while the glass and stainless steel finish is easily wiped clean. The SmartHQ™ app will notify you when to clean the filters to ensure you get the best performance out of your rangehood.

Considered Efficiency

The right amount of air is extracted to effectively remove cooking odours with reduced effect on your heating or air conditioning.

SPECIFICATIONS

Accessories (included)

Aluminium filter	792943
External motor kit	50170 HB 1200E* (included)

Accessories (sold separately)

Extra ducting length	792961
Light bulb	requires service to replace

Fan ratings

Maximum air movement **1200 m³/hr**

Installation and cleaning

Air outlet size **200 mm**

Dishwasher safe filters **2**

Ducted **Top extraction**

Performance

Extraction type **Perimeter**

Fan speeds **4**

Fan speeds + boost **•**

Filter type **Mesh with perimeter extraction**

Number of filters **2**

Power requirements

Supply frequency **50 Hz**

Supply voltage **240 V**

Product dimensions

Depth **280 mm**

Height **316 mm**

Width **830 mm**

Product information

Control type

Capacitive touch

Ventilation features

Auto-off/Run-on timer **•**

Dimmable lights **•**

Filter cleaning alert **•**

Light type **LED strip**

Timer function **•**

Warranty

Parts and labour **2 years**

SKU **50192**

The product dimensions and specifications in this page apply to the specific product and model. Under our policy of continuous improvement, these dimensions and specifications may change at any time. You should therefore check with Fisher & Paykel's Customer Care Centre to ensure this page correctly describes the model currently available. © Fisher & Paykel Appliances Ltd 2020

Other product downloads available at fisherpaykel.com

- [↓](#) 2D-DWG Insert Rangehood
- [↓](#) 2D-DXF Insert Rangehood
- [↓](#) Data Sheet Insert Rangehood
- [↓](#) Service & Warranty
- [↓](#) Preliminary Specification Guide Rangehood
- [↓](#) User Guide Integrated Insert Rangehood

Where applicable:

All appliances use energy, and energy usage typically generates carbon emissions. **Fisher & Paykel Appliances' In-use Energy Carbon Emissions Estimate** indicates carbon emissions from a product's in-use energy. This is calculated either annually or per cycle, using the product's market-specific energy label energy consumption data multiplied by the carbon emissions factor for energy in your country or region.

Our In-use Energy Carbon Emissions Estimate is designed to assist customers in making informed purchasing decisions when comparing different Fisher & Paykel products. For example, a heat pump dryer typically has a lower In-use Energy Carbon Emissions Estimate than a vented dryer.



A PEACE OF MIND SALE
24 Hours 7 Days a Week Customer Support
 T 0800 372 273 W www.fisherpaykel.com