

Freestanding Quad Door Refrigerator Freezer, 90.5cm, 690L, Ice & Water

Series 7 | Contemporary

Black Glass | French hinge



Our largest capacity Quad Door model has ample storage space and Variable Temperature Zone technology, with a matte-black glass finish.

- Elegant matte-black glass finish, with recessed handles for a streamlined look
- 4 star energy rating
- Convenient access to fresh, chilled water and ice

- Easy-to-use touch control panel and Wi-Fi capability
- Extra large capacity, with Variable Temperature Zone technology for optimal food storage

DIMENSIONS

Height	1900 mm
Width	905 mm
Depth	748 mm

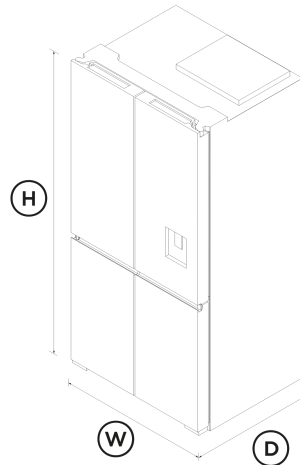

FEATURES & BENEFITS

Extra Large Capacity

With extra large capacity and flexible shelving, this refrigerator freezer has plenty of room for you to stack and organise all your groceries. Three large humidity bins in the fridge provide ample space for fresh fruit and vegetables, while fully extendable freezer drawers give easy access to frozen foods.

Variable Temperature Zone

When it comes to optimal food preservation, one temperature does not fit all. Variable Temperature Zones give you full control over the way you care for food. At the touch of a button, easily convert the lower right compartment to Freezer, Soft Freeze, Chill or Fridge mode to best suit different types of food. Adjust zones for maximum everyday convenience, or change modes to provide additional chilling capacity for special occasions.

Chill Mode

Keep ready-to-eat food fresher for longer with Chill Mode (-2 to 1°C). Chill Mode is a perfect solution for everyday life. It keeps meats, poultry and fish as cool as possible, retaining vital freshness and helps food retain its condition for around three times longer than Fridge Mode. It's also great for entertaining. Set a zone to Chill Mode to quickly bring beverages down to serving temperature.

Soft Freeze Mode

Soft freeze (-9 to -5°C) is perfect for food that will be consumed soon - but not right away. Set a zone to Soft Freeze Mode and enjoy optimal food storage and everyday convenience. Soft frozen food requires only a quick thaw rather than a full defrost. It is the ideal setting for easy portioning, such as cut loaves of bread, soups and even cured meats.

Slimline Water Dispenser And Ice Maker

The slimline dispenser makes it easy to fill almost any sized jug or vessel with cool filtered water, while fresh ice is always available for you in a dedicated freezer bin. Use the boost feature during busy times to increase ice production.

Activesmart™ Foodcare

ActiveSmart™ Foodcare learns how you live. It is technology that understands how you use your fridge and adjusts temperature, airflow and humidity inside to help keep food fresher for longer.

Considered Design

Designed to match our Contemporary style black glass family of products, this refrigerator freezer has a tactile matte-black glass finish that pairs perfectly with recessed handles.

SPECIFICATIONS

Accessories (sold separately)

Water filter replacement **847200 - FWC3**

Capacity

Total gross capacity **744 L**
 Volume **690 L**
 Volume freezer **118 L**
 Volume refrigerator **453 L**
 Volume variable temperature compartment **119 L**

Consumption

Energy rating **4 star**
 Energy usage **463kWh/year**
 In-use energy carbon emissions estimate **301.6kgCO2e/year**

Features

Adjustable door shelves **6**
 Adjustable glass shelves **2**
 Door alarm **•**
 Front levelling feet **•**
 Fruit and vegetable bins **3**
 Full extension runners **•**
 LED lighting **•**
 Rear rollers **•**
 Smart appliance AU NZ **•**
 SmartTouch control panel **•**
 Ultra slim water dispenser **•**
 Wi-Fi connectivity **•**

Freezer Features

Automatic ice maker **•**
 Bottle chill **•**
 Door alarm **•**
 Fast freeze **•**
 Freezer bins **1**
 Freezer trays **1**
 Full extension clear bins **1**
 Ice bin and scoop **•**
 Ice Boost **•**
 LED Lighting **•**

Installation Dimensions

Minimum inside width of cabinetry frame **945 mm**
 Minimum internal depth of cabinetry **690 mm**

Minimum internal height of cabinetry **1920 mm**

Performance

ActiveSmart™ Foodcare **•**
 Frost free freezer **•**
 Humidity control system **•**
 Internal replacable water filter **•**
 Inverter controlled compressor **•**
 R600a refrigerant **•**
 Sabbath mode **•**
 Variable Temperature Compartment Performance **•**

Power requirements

Rated current **1.8 A**
 Supply voltage **220 - 240 V**

Product dimensions

Depth **748 mm**
 Depth (less door) **660 mm**
 Height **1900 mm**
 Height to top of cabinet **1900 mm**
 Height to top of door **1068 mm**
 Minimum air clearance - at rear **30 mm**
 Minimum air clearance - each side **20 mm**
 Minimum air clearance - on top **20 mm**
 Width **905 mm**

Variable Temp Compartment

Chill (mode)	•
Freezer (mode)	•
Fridge (mode)	•
Full extension clear bins	1
Soft freeze	•

- [↓](#) Rhino Freestanding Quad Door Refrigerator Freezer
- [↓](#) Sketchup Freestanding Quad Door Refrigerator Freezer
- [↓](#) Specification Guide Freestanding Quad Door Refrigerator Freezer
- [↓](#) User Guide Freestanding Quad Door Refrigerator Freezer

Warranty

Parts and labour	2 years
------------------	----------------

Where applicable:

All appliances use energy, and energy usage typically generates carbon emissions. **Fisher & Paykel Appliances' In-use Energy Carbon Emissions Estimate** indicates carbon emissions from a product's in-use energy. This is calculated either annually or per cycle, using the product's market-specific energy label energy consumption data multiplied by the carbon emissions factor for energy in your country or region.

Our In-use Energy Carbon Emissions Estimate is designed to assist customers in making informed purchasing decisions when comparing different Fisher & Paykel products. For example, a heat pump dryer typically has a lower In-use Energy Carbon Emissions Estimate than a vented dryer.

SKU	26614
-----	-------

The product dimensions and specifications in this page apply to the specific product and model. Under our policy of continuous improvement, these dimensions and specifications may change at any time. You should therefore check with Fisher & Paykel's Customer Care Centre to ensure this page correctly describes the model currently available. © Fisher & Paykel Appliances Ltd 2020



A PEACE OF MIND SALE
24 Hours 7 Days a Week Customer Support

T 1300 650 590 W www.fisherpaykel.com

Other product downloads available at fisherpaykel.com

- [↓](#) 2D-DWG Freestanding Quad Door Refrigerator Freezer
- [↓](#) 2D-DXF Freestanding Quad Door Refrigerator Freezer
- [↓](#) Data Sheet Quad Door Refrigerator Freezer
- [↓](#) Energy Label Freestanding Refrigerator Freezer
- [↓](#) Energy Label
- [↓](#) Service & Warranty
- [↓](#) Installation Guide Freestanding Quad Door Refrigerator Freezer
- [↓](#) Revit Freestanding Quad Door Refrigerator Freezer