

413L Series 5 Refrigerator Freezer

Series 5 | Contemporary

Stainless Steel | Right Hinge



With stylish contemporary design and generous, flexible storage for all your chilled and frozen foods.

- ActiveSmart™ technology helps keep food fresher for longer by constantly maintaining the ideal temperature.
- Ultra flat door conceals handles for streamlined look
- Spacious bottom freezer with easy-slide internal drawers to separate storage

DIMENSIONS

Height	1720 mm
Width	680 mm
Depth	695 mm

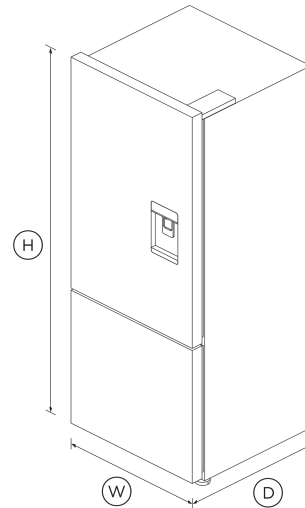

FEATURES & BENEFITS

Activesmart™ Foodcare

ActiveSmart™ Foodcare learns how you live. It's technology which understands how you use your refrigerator and adjusts temperature, airflow and humidity inside to help keep food fresher for longer.

Clever Energy

Your refrigerator adapts to daily use by cooling and defrosting only when needed. This means your refrigerator uses the energy it needs without compromising on food care.

Humidity Control

Your fruit and veges need different environments. The humidity control slides in each storage bin create a microclimate that helps keep food fresher for longer.

Ice maker

Fresh ice is always available for you in a dedicated freezer bin. Simply turn it off to free up freezer space or during busy times, you can boost ice production by up to 30%.

WATER ON TAP

The slimline dispenser makes it easy to fill almost any sized jug or vessel with cool filtered water and doesn't take up any storage space in your refrigerator.

Design Quality

Our refrigerators are designed and built using quality materials. We use real stainless steel on our refrigerators and solid glass for shelving.

SPECIFICATIONS

Capacity

Total gross capacity	442 L
Volume	413 L
Volume freezer	119 L
Volume refrigerator	294 L

Consumption

Energy rating	3 star
Energy usage	433kWh/year
In-use energy carbon emissions estimate	58.6kgCO2e/year

Features

Adjustable door shelves	4
Adjustable glass shelves	4
Covered door shelves	2
Door alarm	•
Front levelling feet	•
Fruit and vegetable bins	2
LED lighting	•
Rear rollers	•
Single bottle holders	2
SmartTouch control panel	•
Stackable bottle holders	2
Ultra slim water dispenser	•

Inverter controlled compressor •

Product dimensions

Depth	695 mm
Height	1720 mm
Height to top of cabinet	1720 mm
Height to top of door	1720 mm
Minimum air clearance - at rear	30 mm
Minimum air clearance - each side	20 mm
Minimum air clearance - on top	50 mm
Width	680 mm

Freezer Features

Automatic ice maker	•
Bottle chill	•
Door alarm	•
Fast freeze	•
Ice bin and scoop	•
Ice Boost	•
Large plastic bins	•
Slide Out Pastry Tray	•
Small plastic bins	•

Warranty

Parts and labour	2 years
Sealed system parts only	5 years

SKU 26376

The product dimensions and specifications in this page apply to the specific product and model. Under our policy of continuous improvement, these dimensions and specifications may change at any time. You should therefore check with Fisher & Paykel's Customer Care Centre to ensure this page correctly describes the model currently available. © Fisher & Paykel Appliances Ltd 2020

Performance

ActiveSmart™ Foodcare	•
Adaptive defrost	•
Frost free freezer	•
Humidity control system	•

Other product downloads available at fisherpaykel.com

↓ 2D-DWG Freestanding Refrigerator Freezer

- ↓ 2D-DXF Freestanding Refrigerator Freezer
- ↓ Data Sheet Freestanding Refrigerator Freezer
- ↓ Service & Warranty
- ↓ Water Filter Replacement Instructions - Parts 862285 and 862288 - EN
- ↓ Installation Guide

Where applicable:

All appliances use energy, and energy usage typically generates carbon emissions. **Fisher & Paykel Appliances' In-use Energy Carbon Emissions Estimate** indicates carbon emissions from a product's in-use energy. This is calculated either annually or per cycle, using the product's market-specific energy label energy consumption data multiplied by the carbon emissions factor for energy in your country or region.

Our In-use Energy Carbon Emissions Estimate is designed to assist customers in making informed purchasing decisions when comparing different Fisher & Paykel products. For example, a heat pump dryer typically has a lower In-use Energy Carbon Emissions Estimate than a vented dryer.



A PEACE OF MIND SALE
24 Hours 7 Days a Week Customer Support
 T 0800 372 273 Wwww.fisherpaykel.com