

Combination Microwave Oven, 60cm, 22 Function

Series 9 | Contemporary

Stainless Steel



The speed of microwave cooking with the versatility of convection oven technology in a compact companion model, for perfect pairing.

- Generous 49L capacity, with four shelf positions
- A Wired Temperature Sensor precisely monitors cooking in real time
- Guided touchscreen cooking makes it simple to navigate cooking processes

- Wi-Fi enabled and works with the SmartHQ™ app for remote control and notifications

DIMENSIONS

Height	458 mm
Width	596 mm
Depth	565 mm

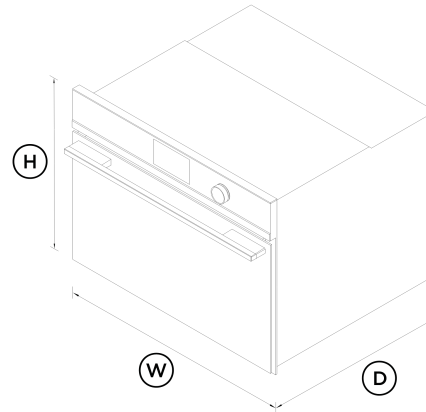

FEATURES & BENEFITS

Cooking Flexibility

Choose from 22 functions, including four microwave-only functions, 14 traditional oven functions, and four combination functions, giving you the best microwave and convection oven technology.

Cook With Confidence

The 5" screen provides an intuitive guided cooking experience that helps to deliver perfect results, whether you've been cooking all your life or are just starting out.

Sized To Suit

A compact 60cm width means this microwave oven can be placed almost anywhere – all companion products can be installed at a convenient height to suit your kitchen design and preference.

Complementary Design

Finished in stylish stainless steel with a polished metal trim, our Contemporary style ovens help you to create a coherent, distinctive aesthetic in your kitchen.

Multi-Function Flexibility

Each function has been tailored and tested to ensure perfect defrosting, heating and cooking.

Safe And Sound

The CoolTouch door is safe to touch from the outside, protecting your hands and the surrounding cabinetry.

SPECIFICATIONS

Accessories (included)

Chromed shelf runners	•
Glass tray	1
Step down wire shelf	1
Wire shelf	1
Wired temperature sensor	1

Capacity

Shelf positions	4
Total capacity	49 L

Usable capacity **38 L**

Cleaning

- Acid resistant graphite enamel
- Removable oven door
- Removable oven door inner glass
- Removable shelf runners

Controls

- Adjustable audio and display settings
- Audio feedback
- Automatic cooking/minute timer
- Automatic pre-set temperatures
- Certified Sabbath mode
- Delay start
- Electronic clock
- Electronic oven control
- Food probe
- Guided cooking by food types
- Halogen lights
- Intuitive touchscreen display
- Multi-language display **UK English, US English, Simplified Chinese, Français, Español**
- Smart appliance
- Soft close doors
- Turned stainless steel dials with illuminated halos
- Wi-Fi connectivity

Wireless temperature sensor compatible •

Functions

- Air fry
- Bake
- Defrost
- Dehydrate
- Fan bake
- Fan forced
- Fan forced + Micro (3 levels)
- Fan grill
- Fan grill + Micro (3 levels)
- Grill
- Grill + Micro (3 levels)
- Microwave cooking
- Number of functions **22**
- Pastry Bake
- Pizza bake
- Popcorn
- Quick start
- Rapid proof
- Roast
- Roast + Micro (3 levels)
- Slow cook
- Vent bake
- Warm

Performance

- ActiveVent™ system

- AeroTech™ technology
- Automatic rapid pre-heat
- Grill power **3000 W**
- Microwave by levels
- Microwave power **900 W**
- Microwave power levels **6**
- Temperature range **35 - 230°C**
- Whisper Quiet Cooking

Power requirements

- Amperage **16 A**
- Supply frequency **50 Hz**
- Supply voltage **220-240 V**

Product dimensions

- Depth **565 mm**
- Height **458 mm**
- Width **596 mm**

Safety

- Balanced oven door
- Control panel key lock
- CoolTouch door
- Non-tip shelves
- Safety thermostat

Warranty

Parts and labour **2 years**



A PEACE OF MIND SALE
24 Hours 7 Days a Week Customer Support
T +65 6741 0777 W www.fisherpaykel.com

SKU 82669

The product dimensions and specifications in this page apply to the specific product and model. Under our policy of continuous improvement, these dimensions and specifications may change at any time. You should therefore check with Fisher & Paykel's Customer Care Centre to ensure this page correctly describes the model currently available. © Fisher & Paykel Appliances Ltd 2020

Other product downloads available at fisherpaykel.com

[↓](#) Service & Warranty

Where applicable:

All appliances use energy, and energy usage typically generates carbon emissions. **Fisher & Paykel Appliances' In-use Energy Carbon Emissions Estimate** indicates carbon emissions from a product's in-use energy. This is calculated either annually or per cycle, using the product's market-specific energy label energy consumption data multiplied by the carbon emissions factor for energy in your country or region.

Our In-use Energy Carbon Emissions Estimate is designed to assist customers in making informed purchasing decisions when comparing different Fisher & Paykel products. For example, a heat pump dryer typically has a lower In-use Energy Carbon Emissions Estimate than a vented dryer.