

# 60cm Series 3 Contemporary Oven, 5 Function

Series 3 | Contemporary

Stainless Steel



With contemporary styling and clean lines in glass and steel, this built-in oven complements the style and elegance of any modern kitchen.

- 85L total capacity
- Five oven functions including Maxi Grill

## DIMENSIONS

Height	598 mm
Width	597 mm
Depth	565 mm

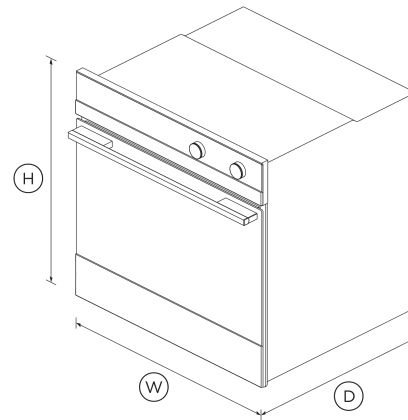

## SPECIFICATIONS

### Accessories (included)

- Catalytic panels

### Accessories (sold separately)

Handle kit Contemporary round, aluminium **Part number 81645**

Capacity

Shelf positions	6
Total capacity	85 L
Usable capacity	72 L

### Cleaning

- Acid resistant graphite enamel
- Drop down grill element
- Removable oven door inner glass

### Controls

- Automatic cooking/minute timer
- Electronic capacitive touch controls
- Halogen lights

### Functions

- Fan forced
- Fan grill
- Grill
- Maxi Grill
- Number of functions **5**

### Performance

- AeroTech™ technology
- Whisper Quiet Cooking

### Power requirements

Amperage **15 A**

- [↓](#) Revit Oven
- [↓](#) Rhino Oven
- [↓](#) Sketchup Oven
- [↓](#) User Guide

**Product dimensions**

Depth **565 mm**

Height **598 mm**

Width **597 mm**

**Where applicable:**

All appliances use energy, and energy usage typically generates carbon emissions. **Fisher & Paykel Appliances' In-use Energy Carbon Emissions Estimate** indicates carbon emissions from a product's in-use energy. This is calculated either annually or per cycle, using the product's market-specific energy label energy consumption data multiplied by the carbon emissions factor for energy in your country or region.

Our In-use Energy Carbon Emissions Estimate is designed to assist customers in making informed purchasing decisions when comparing different Fisher & Paykel products. For example, a heat pump dryer typically has a lower In-use Energy Carbon Emissions Estimate than a vented dryer.

**Safety**

- Balanced oven door •
- CoolTouch door •
- Non-tip shelves •

SKU **81493**



**A PEACE OF MIND SALE**  
**24 Hours 7 Days a Week Customer Support**

T 1300 650 590 [Wwww.fisherpaykel.com](http://www.fisherpaykel.com)

The product dimensions and specifications in this page apply to the specific product and model. Under our policy of continuous improvement, these dimensions and specifications may change at any time. You should therefore check with Fisher & Paykel's Customer Care Centre to ensure this page correctly describes the model currently available. © Fisher & Paykel Appliances Ltd 2020

**Other product downloads available at [fisherpaykel.com](http://fisherpaykel.com)**

- [↓](#) 2D-DWG Oven
- [↓](#) 2D-DXF Oven
- [↓](#) Archicad Oven
- [↓](#) Data Sheet Oven
- [↓](#) Service & Warranty
- [↓](#) Installation Guide Built-In Oven