

Top Loader Washing Machine, 7kg

Series 5 | Top load

White



A powerful, quiet washing machine with SmartDrive™ technology, caring for all fabric types.

- Four wash cycles including Wool and Delicate
- With SmartDrive™ technology for a quiet and reliable wash
- 7kg capacity

DIMENSIONS

Height	1045 - 1075 mm
Width	600 mm
Depth	600 mm

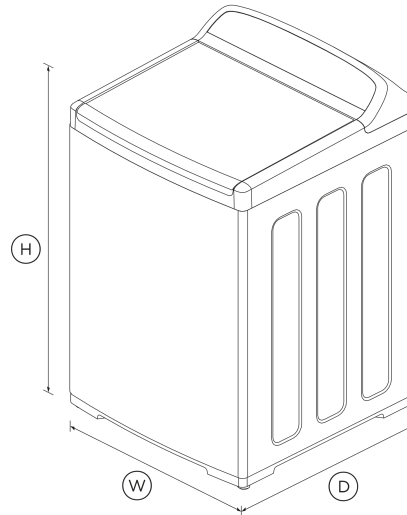

FEATURES & BENEFITS

Smartdrive™ Technology

Our world-first SmartDrive™ technology is made up of just three main parts. This means our washing machines can sense each load, use less water and run with less moving parts for greater reliability.

Easy To Use

This machine has four wash cycles to suit a variety of fabric types: Delicate, Heavy, Regular and Wool. Select a cycle with easy to use SmartTouch™ controls.

Easy Installation

Self-levelling feet make installation easy and ensure the washer stays level to reduce vibration keeping noise to a minimum.

Cares For Clothes

The flexible finned agitator ensures less tangling for superior clothes care.

Quicker Drying

Drying times are reduced due to a fast spin speed of 1000RPM which helps remove more water.

SPECIFICATIONS

Capacity

Capacity **7 kg**

Consumption

Energy rating	2 star
Energy usage	580kWh/year
In-use energy carbon emissions estimate	78.5kgCO2e/year
Water consumption per cycle	86L
Water rating	3.5 star (WELS)

Features

Agitator	Flexible finned
Auto out of balance correction	•
Child/Keylock	•
Detergent dispenser	•
Eco rinse	•
Fabric softener dispenser	•

Lid lock	•
Manual water levels	3
No Spin / Spin hold	•
Rinse options	2
SmartTouch™ control dial	•
Spin speeds	3
Stainless steel drum	•
Water temperature controls	3

Conventional	•
Customise cycle	•
Delicate	•
Heavy	•
Number of wash cycles	4
Regular	•
Wool	•

All appliances use energy, and energy usage typically generates carbon emissions. **Fisher & Paykel Appliances' In-use Energy Carbon Emissions Estimate** indicates carbon emissions from a product's in-use energy. This is calculated either annually or per cycle, using the product's market-specific energy label energy consumption data multiplied by the carbon emissions factor for energy in your country or region.

Our In-use Energy Carbon Emissions Estimate is designed to assist customers in making informed purchasing decisions when comparing different Fisher & Paykel products. For example, a heat pump dryer typically has a lower In-use Energy Carbon Emissions Estimate than a vented dryer.

Performance

SKU 92265

Auto-Lint disposal	•
Load sensing	•
Maximum spin speed	1000 rpm
Number of spin speeds	3
SmartDrive™ technology	•

The product dimensions and specifications in this page apply to the specific product and model. Under our policy of continuous improvement, these dimensions and specifications may change at any time. You should therefore check with Fisher & Paykel's Customer Care Centre to ensure this page correctly describes the model currently available. © Fisher & Paykel Appliances Ltd 2020



A PEACE OF MIND SALE
24 Hours 7 Days a Week Customer Support
 T 0800 372 273 W www.fisherpaykel.com

Product dimensions

Depth	600 mm
Height	1045 - 1075 mm
Height (Lid open)	1350 - 1380mm
Width	600 mm

Other product downloads available at fisherpaykel.com

- [↓ Energy & Water Label](#)
- [↓ Service & Warranty](#)
- [↓ Installation Guide](#)
- [↓ User Guide](#)

Warranty

Where applicable:

Parts and labour	2 years
Parts only SmartDrive™ motor	10 years

Wash Cycles