

# 60cm Series 7 Contemporary Pyrolytic Oven, 11 Function

Series 7 | Contemporary

Stainless Steel



With beautiful Contemporary styling and generous capacity, this built-in oven helps to ensure that every dish you create is cooked to perfection.

- 85L total capacity with 11 oven functions including Pizza Bake, Roast, Slow Cook and Air Fry
- Moisture level control with ActiveVent technology

- Pyrolytic self-cleaning function breaks down food residue for an easy clean
- Wi-Fi enabled for remote control and notifications through the SmartHQ™ app

## DIMENSIONS

Height	598 mm
Width	596 mm
Depth	565 mm

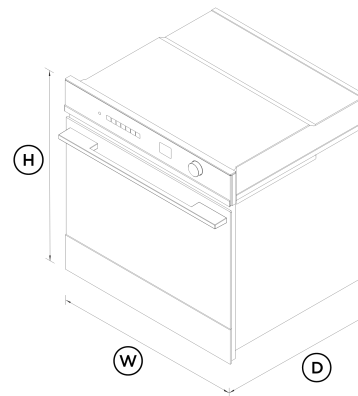

## FEATURES & BENEFITS

### Multi-Function Flexibility

Each function has been perfected to ensure that no matter what you're cooking, you've got the right heat to match. This built-in oven has 11 functions including Pizza Bake, Roast, Slow Cook and Air Fry, allowing you to use a variety of cooking styles.

### Generous Capacity

With a generous 85L total capacity, you can create several perfectly cooked dishes at once using multiple shelves.

### Cook With Confidence

The intuitive 2.4" screen provides an intuitive guided cooking experience that helps to deliver perfect results, whether you've been cooking all your life or are just starting out. Cook by food type and allow your oven to guide you through steps, or change temperature and heat type automatically, depending on your selection.

### Exceptional performance

Our unique cooking technologies were developed to deliver perfect results. ActiveVent ensures optimised moisture levels, while AeroTech™ circulates heat evenly for a consistent temperature.

### Self-Cleaning

Pyrolytic self-clean breaks down food residue at a very high temperature, leaving a light ash that's easily removed with a damp cloth. The chrome side racks don't need to be removed when using this function.

### Design Freedom

Designed to fit seamlessly into your kitchen, this built-in oven features premium materials and detailing to support a cohesive, considered kitchen design.

### Safe And Sound

The CoolTouch door features triple glazing and a cooling system that ensures it's safe to touch from the outside - protecting both your hands and the surrounding cabinetry.

**SPECIFICATIONS**

**Accessories (included)**

Chromed shelf runners	•
Full extension sliding shelves	<b>1 set</b>
Grill rack	<b>1 set</b>
Roasting dish	<b>1</b>
Step down wire shelf	<b>1</b>
Wire shelf	<b>1</b>

**Capacity**

Shelf positions	<b>6</b>
Total capacity	<b>85 L</b>
Usable capacity	<b>72 L</b>

**Cleaning**

Acid resistant graphite enamel	•
Pyrolytic self-clean	•
Removable oven door	•
Removable oven door inner glass	•
Removable shelf runners	•

**Consumption**

Energy rating	<b>A</b>
Energy usage	<b>0.94kWh/cycle</b>
In-use energy carbon emissions estimate	<b>0.2kgCO2e/cycle</b>

**Controls**

Adjustable audio and display settings	•
Audio feedback	•
Automatic cooking/minute timer	•
Automatic pre-set temperatures	•
Celsius/Fahrenheit temperature	•
Delay start	•
Electronic clock	•
Electronic oven control	•
Halogen lights	•
Multi-language display	•

**UK English, US English, Simplified Chinese, Français, Español**

Sabbath mode with Federation of Synagogues certification	•
Smart appliance	•
Soft close doors	•
True convection oven	•
Turned stainless steel dials with illuminated halos	•
Wireless temperature sensor compatible	•

**Functions**

Air fry	•
Bake	•
Fan bake	•
Fan forced	•
Fan grill	•
Grill	•
Number of functions	<b>11</b>
Pizza bake	•

Pyrolytic self-clean	•
Roast	•
Slow cook	•
Vent bake	•

**Performance**

ActiveVent™ system	•
AeroTech™ technology	•
Automatic rapid pre-heat	•
Grill power	<b>3000 W</b>
Temperature range	<b>50°C - 280°C</b>
Whisper Quiet Cooking	•

**Power requirements**

Amperage	<b>15 A</b>
Supply frequency	<b>50 Hz</b>
Supply voltage	<b>220-240 V</b>

**Product dimensions**

Depth	<b>565 mm</b>
Height	<b>598 mm</b>
Width	<b>596 mm</b>

**Safety**

Balanced oven door	•
Catalytic venting system	•
Control panel key lock	•

CoolTouch door	•
Non-tip shelves	•
Safety thermostat	•

---

### Warranty

Parts and labour	<b>5 years</b>
------------------	----------------

---

SKU	82751
-----	-------

---

The product dimensions and specifications in this page apply to the specific product and model. Under our policy of continuous improvement, these dimensions and specifications may change at any time. You should therefore check with Fisher & Paykel's Customer Care Centre to ensure this page correctly describes the model currently available. © Fisher & Paykel Appliances Ltd 2020

### Where applicable:

All appliances use energy, and energy usage typically generates carbon emissions. **Fisher & Paykel Appliances' In-use Energy Carbon Emissions Estimate** indicates carbon emissions from a product's in-use energy. This is calculated either annually or per cycle, using the product's market-specific energy label energy consumption data multiplied by the carbon emissions factor for energy in your country or region.

Our In-use Energy Carbon Emissions Estimate is designed to assist customers in making informed purchasing decisions when comparing different Fisher & Paykel products. For example, a heat pump dryer typically has a lower In-use Energy Carbon Emissions Estimate than a vented dryer.



**A PEACE OF MIND SALE**  
**24 Hours 7 Days a Week Customer Support**  
 T 08000 886 605 W [www.fisherpaykel.com](http://www.fisherpaykel.com)

### Other product downloads available at [fisherpaykel.com](http://fisherpaykel.com)

- [↓ 2D-DWG Oven](#)
- [↓ 2D-DXF Oven](#)
- [↓ ArchiCAD Oven](#)
- [↓ Datasheet Oven](#)
- [↓ Declaration of Conformity Oven](#)
- [↓ Service & Warranty](#)
- [↓ Installation Guide Wall Oven](#)
- [↓ Product Information Sheet Oven](#)
- [↓ Revit Oven](#)
- [↓ Rhino Oven](#)
- [↓ SketchUp Oven](#)
- [↓ Preliminary Specification Guide Wall Oven](#)
- [↓ User Guide Convection Oven](#)