

# Freestanding Refrigerator Freezer, 79cm, 490L, Ice & Water

Series 5 | Contemporary

Stainless Steel | Right Hinge



With ample storage and a stylish stainless steel finish, for a timeless look.

- ActiveSmart technology helps keep food fresher for longer by constantly maintaining the ideal temperature.
- Spacious bottom freezer with easy-slide internal drawers to separate storage
- Door water dispenser and internal ice maker

## DIMENSIONS

Height	1715 mm
Width	790 mm
Depth	695 mm

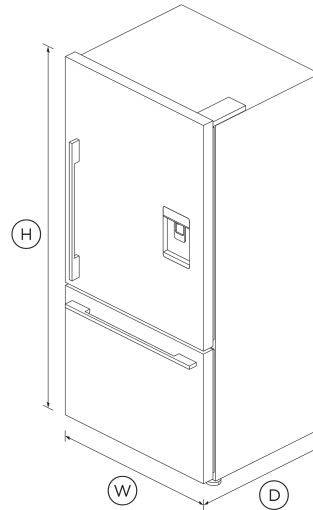

## FEATURES & BENEFITS

### Activesmart Foodcare

Every time you open your refrigerator, the temperature around your food changes. ActiveSmart foodcare adjusts airflow to create a stable temperature, helping your food stay fresher for longer.

### Water Dispenser

The slimline dispenser makes it easy to fill almost any sized jug or vessel with cool filtered water and doesn't take up any storage space in your refrigerator.

### Ice Maker

Fresh ice is always available for you in a dedicated freezer bin. Simply turn it off to free up freezer space or during busy times, you can boost ice production by up to 30%.

### Design quality

Our fridges are designed and built using quality materials. We use real stainless steel on our fridges and solid glass for shelving.

### Easy Cleaning

No more permanent dirty marks with our EZKleen feature for stainless steel refrigerators. Anti-fingerprint coating means you simply wipe clean any marks. Spill-safe secure glass shelves easily capture any drips or leaks.

### Simple Storage

This refrigerator is designed to make it simple for you to store, access and remove food. Storage bins give you full access inside when they're pulled open and can be easily removed to clean. Our flexible shelving also gives you more storage options.

### Clever Energy

Your refrigerator adapts to daily use by cooling and defrosting only when needed. This ActiveSmart™ technology means better energy efficiency without compromising on food care.

## SPECIFICATIONS

### Capacity

Total net volume	490L
Volume freezer	142 L
Volume refrigerator	348 L

### Consumption

Energy rating **Grade 2**

**Features**

Adjustable door shelves	4
Adjustable glass shelves	4
Adjustable half width door shelves	2
Covered door shelves	2
Door alarm	•
Front levelling feet	•
Full extension runners	•
Full width door shelves	2
LED lighting	•
Rear rollers	•
Single bottle holders	4
SmartTouch control panel	•
Ultra slim water dispenser	•

**Freezer Features**

Automatic ice maker	•
Bottle chill	•
Door alarm	•
Fast freeze	•
Ice bin and scoop	•
Ice Boost	•
Large plastic bins	•
Small plastic bins	•

**Performance**

ActiveSmart™ Foodcare	•
Adaptive defrost	•
Frost free freezer	•
Humidity control system	•
Inverter controlled compressor	•
R600a refrigerant	•
Sabbath mode	•

**Power requirements**

Connection power	<b>240W</b>
Supply voltage	<b>220 - 240 V</b>

**Product dimensions**

Depth	<b>695 mm</b>
Depth (including handles)	<b>735 mm</b>
Height	<b>1715 mm</b>
Minimum air clearance - each side	<b>20 mm</b>
Minimum air clearance - on top	<b>50 mm</b>
Width	<b>790 mm</b>

**Warranty**

Parts and labour	<b>1 year</b>
Sealed system parts only	<b>3 years</b>

SKU 25475

The product dimensions and specifications in this page apply to the specific product and model. Under our policy of continuous improvement, these dimensions and specifications may change at any time. You should therefore check with Fisher & Paykel's Customer Care Centre to ensure this page correctly describes the model currently available. © Fisher & Paykel Appliances Ltd 2020

**Other product downloads available at fisherpaykel.com**

- [↓ Service & Warranty](#)
- [↓ Water Filter Replacement Instructions & Installation Guide EN](#)
- [↓ Installation Guide](#)
- [↓ - Water Filter Replacement ZH](#)
- [↓ ZH](#)
- [↓ Installation Guide](#)
- [↓ Restriction of Hazardous Substances](#)
- [↓ User Guide](#)
- [↓ User Guide](#)
- [↓ Installation & User Guide Refrigerator](#)

**Where applicable:**

All appliances use energy, and energy usage typically generates carbon emissions. **Fisher & Paykel Appliances' In-use Energy Carbon Emissions Estimate** indicates carbon emissions from a product's in-use energy. This is calculated either annually or per cycle, using the product's market-specific energy label energy consumption data multiplied by the carbon emissions factor for energy in your country or region.

Our In-use Energy Carbon Emissions Estimate is designed to assist customers in making informed purchasing decisions when comparing different Fisher & Paykel products. For example, a heat pump dryer typically has a lower In-use Energy Carbon Emissions Estimate than a vented dryer.