

Oven, 90cm, 9 Function, Self-cleaning

Series 9 | Contemporary

Stainless Steel



A highlight of our collection, this large capacity Series 9 oven gives you more room for all kinds of cooking, including Rotisserie.

- 100L total capacity, with 9 oven functions including Rotisserie and Pastry Bake
- Pyrolytic self-cleaning function breaks down food residue for an easy clean
- Built-in professional grade rotisserie
- Non-tip, full-extension shelves for safe removal of hot dishes

DIMENSIONS

| | |
|--------|--------|
| Height | 478 mm |
| Width | 895 mm |
| Depth | 564 mm |

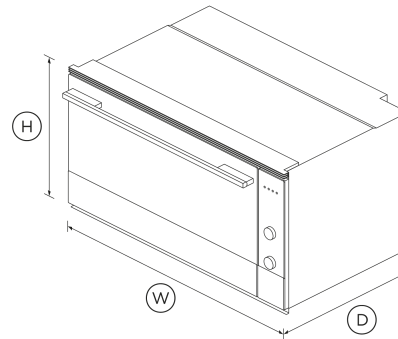

FEATURES & BENEFITS

Cooking Flexibility

This built-in oven has nine functions with pre-set temperatures, including Bake, Pastry Bake and Fan Forced, allowing you to use a variety of cooking styles.

Pre-Set Oven Functions

Oven functions are pre-set at the touch of a dial and brilliant lighting combined with a large viewing window reduce the need to open the oven door, providing perfect cooking results and improving energy efficiency.

Sized To Suit

Designed for multi-shelf cooking, this is one of the largest built-in ovens on the market providing 100L total capacity. The wide cavity allows for both side by side and multi-shelf cooking.

Safe And Sound

The CoolTouch door with triple glazing and cooling system is safe to touch from the outside, protecting your hands and the surrounding cabinetry. Getting large dishes in and out of the oven is a breeze with full telescopic sliding shelves that stay perfectly steady – even when pulled all the way out.

Even Cooking

Our built-in ovens feature AeroTech - a technology that circulates heat evenly, ideal for multi-shelf cooking. The professional-quality rotisserie roasts meat to succulent perfection and a powerful grill gives even and quick browning results.

Complementary Design

With their premium handle styling and stainless steel finish, our built-in ovens are designed to match the rest of Fisher & Paykel's kitchen appliance family.

SPECIFICATIONS

Accessories (included)

| | |
|----------------------|-------|
| Grill rack | 1 set |
| Roasting dish | 1 |
| Rotisserie set | 1 |
| Step down wire shelf | 1 |

Telescopic sliding runners **1 set**

Accessories (sold separately)

Handle kit Contemporary round, aluminium **Part 81649**

Capacity

Shelf positions **4**
 Total capacity **100 L**
 Usable capacity **85 L**

Cleaning

- Acid resistant graphite enamel •
- Pyrolytic self-clean •
- Removable oven door •
- Removable oven door inner glass •
- Removable shelf runners •

Controls

- Audio feedback •
- Automatic cooking/minute timer •
- Automatic pre-set temperatures •
- Celsius/Fahrenheit temperature •
- Electronic clock •
- Electronic oven control •
- Turned stainless capacitive touch buttons with illuminated halos •

Functions

- Bake •
- Fan bake •
- Fan forced •
- Fan grill •
- Grill •
- Number of functions **9**
- Pastry Bake •
- Pyrolytic self-clean •
- Roast •
- Rotisserie •
- Warm •

Performance

- AeroTech™ technology •
- Automatic rapid pre-heat •
- Grill power **4050 W**

Power requirements

Amperage **20.56 A**

Product dimensions

Depth **564 mm**
 Height **478 mm**
 Width **895 mm**

Safety

- Balanced oven door •
- Catalytic venting system •
- Control panel key lock •
- CoolTouch door •
- Non-tip shelves •

SKU **81677**

The product dimensions and specifications in this page apply to the specific product and model. Under our policy of continuous improvement, these dimensions and specifications may change at any time. You should therefore check with Fisher & Paykel's Customer Care Centre to ensure this page correctly describes the model currently available. © Fisher & Paykel Appliances Ltd 2020

Other product downloads available at fisherpaykel.com

- [↓](#) 2D-DWG Oven
- [↓](#) 2D-DXF Oven
- [↓](#) Archicad Oven
- [↓](#) Data Sheet Oven
- [↓](#) Service & Warranty
- [↓](#) Installation Guide
- [↓](#) Revit Oven
- [↓](#) Rhino Oven
- [↓](#) Sketchup Oven
- [↓](#) User Guide

Where applicable:

All appliances use energy, and energy usage typically generates carbon emissions. **Fisher & Paykel Appliances' In-use Energy Carbon Emissions Estimate** indicates carbon emissions from a product's in-use energy. This is calculated either annually or per cycle, using the product's market-specific energy label energy consumption data multiplied by the carbon emissions factor for energy in your country or region.

Our In-use Energy Carbon Emissions Estimate is designed to assist customers in making informed purchasing decisions when comparing different Fisher & Paykel products. For example, a heat pump dryer typically has a lower In-use Energy Carbon Emissions Estimate than a vented dryer.



A PEACE OF MIND SALE
24 Hours 7 Days a Week Customer Support
T +65 6741 0777 [Wwww.fisherpaykel.com](http://www.fisherpaykel.com)