

Freestanding Refrigerator Freezer, 32", 17.5 cu ft

Series 5 | Contemporary

Stainless Steel | Right Hinge

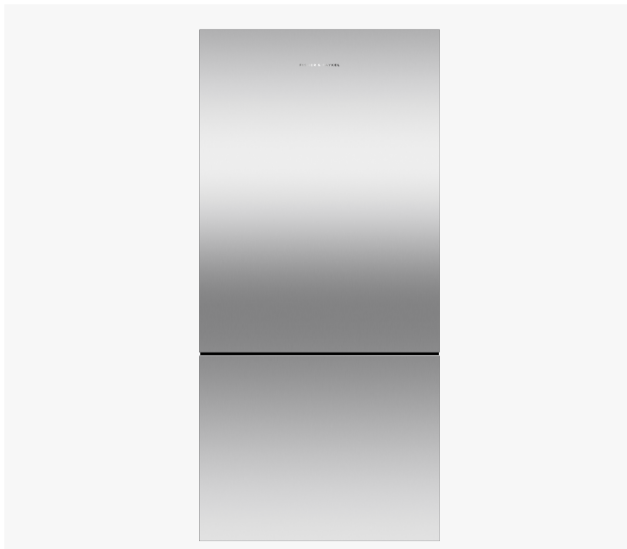

This stylish right hinge refrigerator comes in timeless stainless steel with concealed handles for a more streamlined look.

- Ultra flat door conceals handles for streamlined look
- Bottom freezer
- ActiveSmart™ helps keep food fresher for longer

DIMENSIONS

Height	67 3/4 "
Width	31 1/8 "
Depth	27 3/8 "

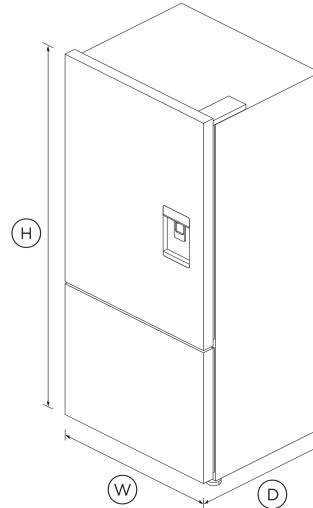

FEATURES & BENEFITS

ActiveSmart™ Foodcare

Every time you open your refrigerator, the temperature around your food changes. ActiveSmart™ foodcare adjusts airflow to create a stable temperature, helping your food stay fresher for longer.

Clever Energy

Your refrigerator adapts to daily use by cooling and defrosting only when needed. This means your refrigerator uses the energy it needs without compromising on food care.

Humidity Control

Your fruit and veges need different environments. The humidity control slides in each storage bin create a microclimate that helps keep food fresher for longer.

Easy Cleaning

No more permanent dirty marks with our EZKleen feature for stainless steel refrigerators. Anti-fingerprint coating means you simply wipe clean any marks. Spill-safe secure glass shelves easily capture any drips or leaks.

Design Quality

Our refrigerators are designed and built using quality materials. We use real stainless steel on our refrigerators and solid glass for shelving.

SPECIFICATIONS

Capacity

Total gross capacity	17.5 cu ft
Volume	17.5 cu ft
Volume freezer	5.2 cu ft
Volume refrigerator	12.3 cu ft

Consumption

Energy rating	Energy star
Energy usage	454kWh/year
In-use energy carbon emissions estimate	56.0kgCO2e/year

Features

Adjustable door shelves	9
Adjustable glass shelves	4
Covered door shelves	2

Door alarm	•	Height	67 3/4 "
Front levelling feet	•	Minimum air clearance at rear	1 3/16 "
Fruit and vegetable bins	2	Minimum air clearance each side	1 3/16 "
LED lighting	•	Minimum air clearance on top	2 "
Rear rollers	•	Width	31 1/8 "
Smart appliance US CA	•		
SmartTouch control panel	•		
Stackable bottle holders	2		
Wi-Fi connectivity	•		

Freezer Features

Bottle chill	•
Door alarm	•
Fast freeze	•
Large plastic bins	•
Slide Out Pastry Tray	•
Small plastic bins	•

Performance

ActiveSmart™ Foodcare	•
Adaptive defrost	•
Frost free freezer	•
Humidity control system	•
Inverter controlled compressor	•
Sabbath mode	•

Product dimensions

Depth	27 3/8 "
-------	-----------------

Variable Temp Compartment

Bottle chill mode	•
-------------------	---

Warranty

Parts and labor	2 years
Sealed system parts & labor	additional 3 years

SKU	26292
-----	-------

The product dimensions and specifications in this page apply to the specific product and model. Under our policy of continuous improvement, these dimensions and specifications may change at any time. You should therefore check with Fisher & Paykel's Customer Care Centre to ensure this page correctly describes the model currently available. © Fisher & Paykel Appliances Ltd 2020

Other product downloads available at fisherpaykel.com

- [↓](#) 2D-DWG Freestanding Refrigerator Freezer
- [↓](#) 2D-DXF Freestanding Refrigerator Freezer
- [↓](#) Data Sheet Freestanding Refrigerator Freezer
- [↓](#) Energy Label
- [↓](#) Service & Warranty

- [↓](#) Installation Guide - Quick Reference EN
- [↓](#) Installation Guide - Joiner Kit EN
- [↓](#) Guide d'installation - Instructions de Remplacement du Filtre à Eau FR
- [↓](#) Guide d'installation - kit de menuisier FR
- [↓](#) Installation Guide
- [↓](#) Guide d'installation FR
- [↓](#) User Guide
- [↓](#) Guide d'utilisation FR

Where applicable:

All appliances use energy, and energy usage typically generates carbon emissions. **Fisher & Paykel Appliances' In-use Energy Carbon Emissions Estimate** indicates carbon emissions from a product's in-use energy. This is calculated either annually or per cycle, using the product's market-specific energy label energy consumption data multiplied by the carbon emissions factor for energy in your country or region.

Our In-use Energy Carbon Emissions Estimate is designed to assist customers in making informed purchasing decisions when comparing different Fisher & Paykel products. For example, a heat pump dryer typically has a lower In-use Energy Carbon Emissions Estimate than a vented dryer.



A PEACE OF MIND SALE
24 Hours 7 Days a Week Customer Support
 T 1.888.936.7872 W www.fisherpaykel.com