

Freestanding French Door Refrigerator Freezer, 90cm, 614L, Ice & Water

Series 7 | Contemporary

Black Stainless Steel | French hinge



Our largest capacity French Door model has intuitive, flexible storage space in a striking black stainless steel finish.

- ActiveSmart™ technology helps keep food fresher for longer by constantly maintaining the ideal temperature.
- Spacious bottom freezer with full extension drawer gives easy access to frozen goods

DIMENSIONS

Height	1790 mm
Width	900 mm
Depth	695 mm

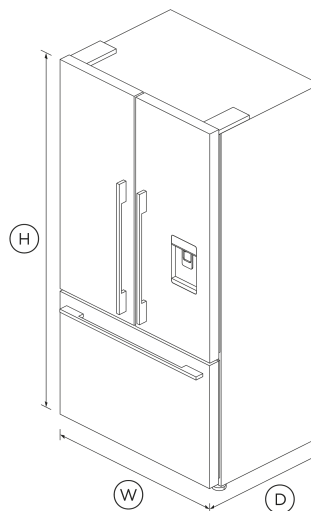

FEATURES & BENEFITS

Clever Energy

Your refrigerator adapts to daily use by cooling and defrosting only when needed. This means it uses the energy it needs without compromising on food care.

Easy Cleaning

No more dirty marks with our EZKleen feature for stainless steel fridges. Anti-fingerprint coating means you simply wipe clean any finger marks. Spill-safe secure glass shelves easily capture any drips or leaks.

Humidity Control

Your fruit and veges need different environments. The humidity control slides in each storage bin create a microclimate that helps keep food fresher for longer.

Design Quality

Our refrigerators are designed and built using the best quality materials. We use real stainless steel, and solid glass for the interior shelving.

Ice Maker

Fresh ice is always available for you in a dedicated freezer bin. Simply turn it off to free up freezer space or, during busy times, boost ice production by up to 30%.

SIMPLE STORAGE

This refrigerator is designed to make it simple for you to store, access and remove food. Storage bins give you full access inside when they're pulled open and can be easily removed to clean. Our flexible shelving also gives you more storage options.

SPECIFICATIONS

Accessories (sold separately)

Water filter replacement	847200 - FWC3
--------------------------	---------------

Capacity

Total gross capacity	614 L
Total net volume	536L
Volume freezer	127 L
Volume refrigerator	409 L

Consumption

Energy consumption	661kWh/year
Energy rating	2 ticks
In-use energy carbon emissions estimate	253.4kgCO ₂ e/year

Performance

- ActiveSmart™ Foodcare
- Adaptive defrost
- Frost free
- Inverter controlled compressor
- R600a refrigerant

Other product downloads available at fisherpaykel.com

- [↓](#) 2D-DWG Freestanding French Door Fridge Freezer
- [↓](#) 2D-DXF Freestanding French Door Fridge Freezer
- [↓](#) Archicad Freestanding French Door Fridge Freezer
- [↓](#) Data Sheet Freestanding French Door Fridge Freezer
- [↓](#) Service & Warranty
- [↓](#) Water Filter Replacement Instructions & Installation Guide EN
- [↓](#) Installation Guide
- [↓](#) Revit Freestanding French Door Fridge Freezer
- [↓](#) Sketchup Freestanding French Door Fridge Freezer
- [↓](#) User Guide
- [↓](#) User & Installation Guide ActiveSmart Refrigerator

Features

Adjustable door shelves	6
Adjustable glass shelves	2
Covered door shelves	2
Deli storage bins	1
Door alarm	•
Front levelling feet	•
Fruit and vegetable bins	2
LED lighting	•
Rear rollers	•
SmartTouch control panel	•
Stackable bottle holders	4
Ultra slim water dispenser	•
Water Filter	Part number 836848

Product dimensions

Depth	695 mm
Height	1790 mm
Height to top of cabinet	1790 mm
Minimum air clearance - at rear	30 mm
Minimum air clearance - each side	20 mm
Minimum air clearance - on top	50 mm
Width	900 mm

Warranty

Parts and labour	2 years
Sealed system parts only	5 years

SKU 26190

The product dimensions and specifications in this page apply to the specific product and model. Under our policy of continuous improvement, these dimensions and specifications may change at any time. You should therefore check with Fisher & Paykel's Customer Care Centre to ensure this page correctly describes the model currently available. © Fisher & Paykel Appliances Ltd 2020

Where applicable:

All appliances use energy, and energy usage typically generates carbon emissions. **Fisher & Paykel Appliances' In-use Energy Carbon Emissions Estimate** indicates carbon emissions from a product's in-use energy. This is calculated either annually or per cycle, using the product's market-specific energy label energy consumption data multiplied by the carbon emissions factor for energy in your country or region.

Our In-use Energy Carbon Emissions Estimate is designed to assist customers in making informed purchasing decisions when comparing different Fisher & Paykel products. For example, a heat pump dryer typically has a lower In-use Energy Carbon Emissions Estimate than a vented dryer.



A PEACE OF MIND SALE
24 Hours 7 Days a Week Customer Support

T +65 6741 0777 W www.fisherpaykel.com