

Convection Speed Oven 24

Series 9 | Minimal

Black



The perfect addition to the kitchen, this Convection Speed Oven provides a variety of fast cooking options including True Convection and Broil.

- 1.3 cu ft total capacity
- Intuitive display with nine oven functions
- Full width grill function
- Easy clean interior

DIMENSIONS

Height	18 1/16 "
Width	23 1/2 "
Depth	22 1/8 "

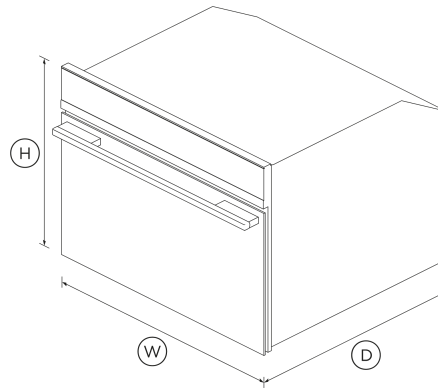

FEATURES & BENEFITS

Sized To Suit

This compact 24" Convection Speed Oven can be placed almost anywhere. Companion products share the same dimensions and can be installed in multiple configurations to suit your kitchen design and preference.

Cooking Flexibility

Choose from nine cooking modes including True Convection and Broil. With both microwave and convection oven technology in the same oven, you have more flexibility for your culinary creations.

Easy To Use

The intuitive touch display shows you all the information you need, allowing you to easily program in your desired cooking mode and duration.

Beauty Of Choice

With the choice of a stylish stainless steel or elegant black trim, our Companion products help you achieve a coherent kitchen aesthetic that suits your design style.

Easy Cleaning

This Convection Speed Oven has formed side racks and a stainless steel interior that are easy to clean.

Safe And Sound

The CoolTouch door is safe to touch from the outside, protecting your hands and the surrounding cabinetry.

SPECIFICATIONS

Accessories (included)

Baking pan	1
Glass turntable	1
Wire shelf	1

Accessories (sold separately)

Matching Trim Kit	TK30NDBB1
Optional lower trim kit	Part 81662

Capacity

Shelf positions	3
Total capacity	1.3 cu ft
Usable capacity	1.2 cu ft

Cleaning

- Easy clean stainless steel interior
- Easy to clean formed side racks

Consumption

Microwave energy consumption **1.65 kWh**

Controls

- Audio feedback
- Automatic cooking/minute timer
- Celsius/Fahrenheit temperature
- Electronic capacitive touch controls
- Electronic oven control
- Intuitive touchscreen display
- True convection oven

Functions

- Broil
- Convection Broil
- Defrost by time
- Defrost by weight
- Microwave + broil
- Microwave + ring
- Microwave cooking
- Number of functions **9**
- Ring + broil
- True convection

Performance

Broil power **1500 W**
 Grill power **1500 W**
 Microwave power **900 W**
 Microwave power levels **6**

Power Requirements

Amperage **15 A**
 Supply frequency **60 Hz**
 Supply voltage **208-240 V**

Product Dimensions

Depth **22 1/8 "**
 Height **18 1/16 "**
 Width **23 1/2 "**

Safety

- ADA compliant
- Control panel key lock
- CoolTouch door

SKU **81926**

The product dimensions and specifications in this page apply to the specific product and model. Under our policy of continuous improvement, these dimensions and specifications may change at any time. You should therefore check with Fisher & Paykel's Customer Care Centre to ensure this page correctly describes the model currently available. © Fisher & Paykel Appliances Ltd 2020

Other product downloads available at fisherpaykel.com

- [↓ 2D-DWG Convection Speed Oven with 30" Trim](#)
- [↓ 2D-DWG Convection Speed Oven with Bottom Trim](#)
- [↓ 2D-DWG Convection Speed Oven](#)
- [↓ 2D-DXF Convection Speed Oven-30inch Trim](#)
- [↓ 2D-DXF Convection Speed Oven with Bottom Trim](#)
- [↓ 2D-DXF Convection Speed Oven](#)
- [↓ Archicad Convection Speed Oven](#)
- [↓ Archicad Convection Speed Oven](#)
- [↓ Archicad Convection Speed Oven](#)
- [↓ Data Sheet Convection Speed Oven with 30inch Trim](#)
- [↓ Data Sheet Convection Speed Oven with Bottom Trim](#)
- [↓ Data Sheet Convection Speed Oven](#)
- [↓ Service & Warranty](#)
- [↓ Installation Guide Companion Products EN](#)
- [↓ Guide d'installation FR](#)
- [↓ Installation Guide - Cavity Trim Kit](#)
- [↓ Preliminary Specification Guide Speed Oven](#)
- [↓ Revit Convection Speed Oven](#)
- [↓ Revit Convection Speed Oven with 24" Trim](#)
- [↓ Revit Convection Speed Oven with 30" Trim](#)
- [↓ Rhino Convection Speed Oven](#)
- [↓ Rhino Convection Speed Oven with 24" Trim](#)
- [↓ Rhino Convection Speed Oven with 30" Trim](#)
- [↓ Sketchup Convection Speed Oven](#)
- [↓ Sketchup Convection Speed Oven with 24" Trim](#)
- [↓ Sketchup Convection Speed Oven with 30" Trim](#)

[↓](#) User Guide**Where applicable:**

All appliances use energy, and energy usage typically generates carbon emissions. **Fisher & Paykel Appliances' In-use Energy Carbon Emissions Estimate** indicates carbon emissions from a product's in-use energy. This is calculated either annually or per cycle, using the product's market-specific energy label energy consumption data multiplied by the carbon emissions factor for energy in your country or region.

Our In-use Energy Carbon Emissions Estimate is designed to assist customers in making informed purchasing decisions when comparing different Fisher & Paykel products. For example, a heat pump dryer typically has a lower In-use Energy Carbon Emissions Estimate than a vented dryer.

**A PEACE OF MIND SALE**

24 Hours 7 Days a Week Customer Support

T 1.888.936.7872 W www.fisherpaykel.com