

Double DishDrawer Dishwasher, Sanitise

Series 9 | Contemporary

Black Glass

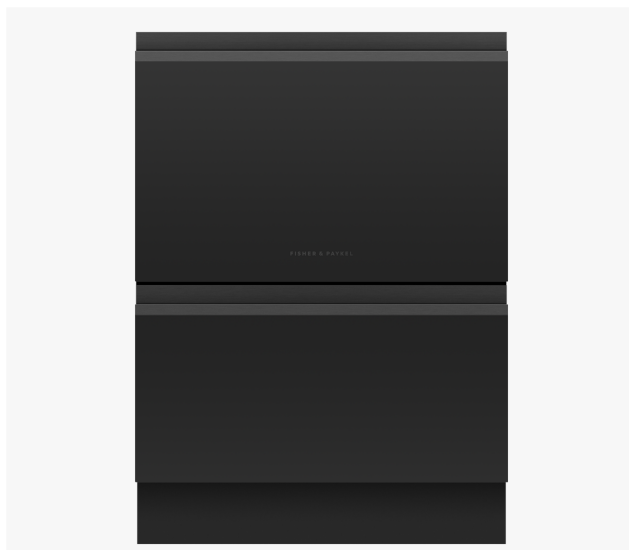

Wash one drawer while you load the other, with room in each drawer for full-size dinner plates.

- Designed to be installed under your benchtop, with recessed handles for a seamless look
- Six wash programs, as well as additional Quick wash, Sanitise and Extra Dry modifiers
- Flexible racking allows you to customise internal shelves to suit your needs

- Wi-Fi enabled and works with the SmartHQ™ app for remote control and notifications

DIMENSIONS

Height	820 - 880 mm
Width	599 mm
Depth	573 mm

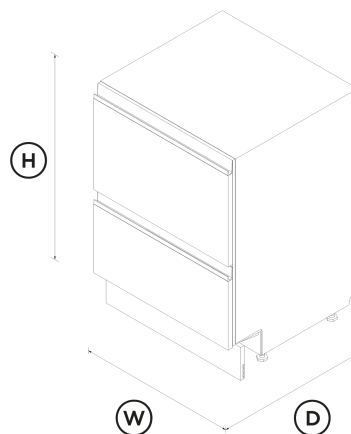

FEATURES & BENEFITS

Considered Design

Designed to match our Contemporary style black glass family of products, this built-under dishwasher has a tactile matte black glass finish that pairs perfectly with recessed handles.

Seamless Fit

Our built-under DishDrawer™ Dishwashers are installed flush under your benchtop with the option of a custom kickstrip, ensuring minimal gaps.

Ease Of Use

DishDrawer™ Dishwashers are as easy to open and close as kitchen drawers and can be conveniently positioned at bench height for ease of loading and minimal bending. Flexible racking allows you to make adjustments to fit in a variety of dishes.

Quick, Sanitise And Extra Dry Options

The Quick wash modifier delivers a faster wash while maintaining performance. The Sanitise option provides extra protection, killing 99.9% of bacteria* in the final rinse. The Extra Dry setting is perfect for plastic dishes.

Knock To Pause

For ease-of-use, these DishDrawer™ Dishwashers have a knock to pause function. A knock on the front panel will pause the dishwasher, which can be restarted by using the start button.

True Half Load

Each drawer holds a true half load for small, fast washing that won't waste water. Both drawers operate independently so two wash cycles can operate simultaneously to allow for varying loads.

Quiet Performer

Running at a very low decibel rating, these DishDrawer™ Dishwashers do their job without making a fuss. The combination of intelligent technology and simple mechanics means greater reliability and excellent wash performance.

SPECIFICATIONS

Accessories (included)

- Cutlery basket

<p>Kickstrip true</p> <p>Knife clip and multipurpose clip •</p> <hr/> <p>Capacity and loading</p> <p>Accommodates round plates up to 280mm</p> <p>Adjustable height, foldable cupracks •</p> <p>Fold down tines •</p> <p>Place settings 14</p> <p>Place settings 14</p> <p>Place settings per drawer 7</p> <p>Place settings per drawer 7</p> <hr/> <p>Consumption</p> <p>Energy rating 3.5 star</p> <p>Energy usage 136kWh/year per drawer</p> <p>In-use energy carbon emissions estimate 18.4kgCO₂e/year per drawer</p> <p>Water rating 4.5 star (WELS)</p> <p>Water usage (per wash cycle) 6.9L per drawer</p> <hr/> <p>Controls</p> <p>Energy saving delay start option of up to 12 hours •</p> <p>Internal wash selector •</p> <p>Keylock •</p> <p>Knock to pause •</p> <p>Rinse aid indicator light •</p> <p>Smart appliance •</p> <p>Wi-Fi connectivity •</p>	<p>Features</p> <p>Fan assisted drying •</p> <p>Flood protection •</p> <p>Flow through detergent dispenser •</p> <p>Motor type BLDC</p> <p>Quiet operation •</p> <p>SmartDrive™ technology •</p> <hr/> <p>Performance</p> <p>Noise on standard cycle top drawer 42 dBA</p> <hr/> <p>Power requirements</p> <p>Amperage 10A</p> <p>Supply frequency 50Hz</p> <p>Supply voltage 220 - 240V</p> <hr/> <p>Product dimensions</p> <p>Depth 573 mm</p> <p>Height 820 - 880 mm</p> <p>Width 599 mm</p> <hr/> <p>Warranty</p> <p>Parts and labour 2 years</p> <hr/> <p>Wash Program Modifiers</p> <p>Extra Dry •</p>	<p>Quick •</p> <p>Sanitise •</p> <p>Wash modifiers 3</p> <hr/> <p>Wash Programs</p> <p>Delicate •</p> <p>Eco •</p> <p>Fast •</p> <p>Heavy •</p> <p>Medium •</p> <p>Rinse •</p> <p>Wash programs 6</p> <hr/> <p>Water connection</p> <p>Water pressure 30kPa - 1000 kPa</p> <p>Water supply 3/4" BSP (20mm) Connector Water Inlet Hose</p> <hr/> <p>SKU 82882</p> <hr/> <p>The product dimensions and specifications in this page apply to the specific product and model. Under our policy of continuous improvement, these dimensions and specifications may change at any time. You should therefore check with Fisher & Paykel's Customer Care Centre to ensure this page correctly describes the model currently available. © Fisher & Paykel Appliances Ltd 2020</p> <p>Other product downloads available at fisherpaykel.com</p>
---	---	---

- [↓ Energy Label DishDrawer™ Dishwasher](#)
- [↓ Service & Warranty](#)
- [↓ Installation Guide Double DishDrawer™ Dishwasher](#)
- [↓ Preliminary Specification Guide Double DishDrawer™ Dishwasher](#)
- [↓ User Guide DishDrawer™ Dishwasher](#)
- [↓ Wash Program Data ASNZS DishDrawer™ Dishwasher](#)

Where applicable:

All appliances use energy, and energy usage typically generates carbon emissions. **Fisher & Paykel Appliances' In-use Energy Carbon Emissions Estimate** indicates carbon emissions from a product's in-use energy. This is calculated either annually or per cycle, using the product's market-specific energy label energy consumption data multiplied by the carbon emissions factor for energy in your country or region.

Our In-use Energy Carbon Emissions Estimate is designed to assist customers in making informed purchasing decisions when comparing different Fisher & Paykel products. For example, a heat pump dryer typically has a lower In-use Energy Carbon Emissions Estimate than a vented dryer.



A PEACE OF MIND SALE
24 Hours 7 Days a Week Customer Support
T 0800 372 273 W www.fisherpaykel.com