

# Freestanding Refrigerator Freezer, 68cm, 396L

Series 5 | Contemporary

White | Right Hinge

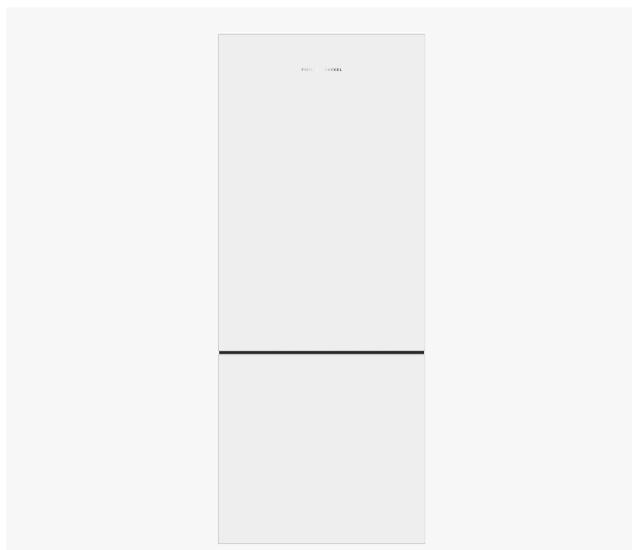

With stylish contemporary design and generous, flexible storage for all your chilled and frozen foods.

- ActiveSmart™ technology helps keep food fresher for longer by constantly maintaining the ideal temperature.
- Spacious bottom freezer with easy-slide internal drawers to separate storage

## DIMENSIONS

Height	1720 mm
Width	680 mm
Depth	695 mm

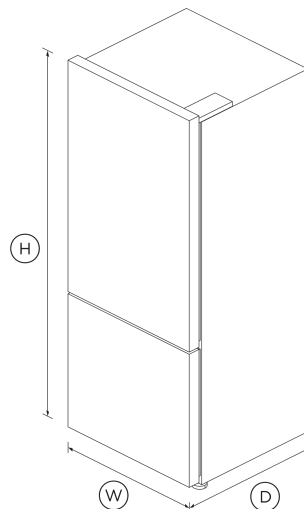

## FEATURES & BENEFITS

### Activesmart™ Foodcare

ActiveSmart™ Foodcare learns how you live. It's technology which understands how you use your refrigerator and adjusts temperature, airflow and humidity inside to help keep food fresher for longer.

### Humidity Control

Your fruit and veges need different environments. The humidity control slides in each storage bin create a perfect microclimate for each, which helps keep them fresher for longer.

### Simple Storage

This refrigerator is designed to make it simple for you to store, access and remove food. Storage bins give you full access inside when they're pulled open and can be easily removed to clean. Our flexible shelving also gives you more storage options.

### Clever Energy

Your refrigerator adapts to daily use by cooling and defrosting only when needed. This means it uses only the energy it needs without compromising on food care.

### Easy Cleaning

Spill-safe secure glass shelves easily capture any drips or leaks and prevent them from falling on items below.

### Design Quality

Our refrigerators are designed and built using quality materials. We use pre-painted steel on our refrigerators and solid glass for shelving.

## SPECIFICATIONS

### Capacity

Total net volume **398L**

### Consumption

Energy consumption **562kWh/year**

Energy rating **2 ticks**

In-use energy carbon emissions estimate **215.4kgCO2e/year**

### Features

Adjustable door shelves **4**

Adjustable glass shelves **4**

Covered door shelves	2	Height to top of cabinet	1698 mm
Door alarm	•	Height to top of door	1720 mm
Front levelling feet	•	Minimum air clearance - at rear	30 mm
Fruit and vegetable bins	2	Minimum air clearance - each side	20 mm
Full extension runners	•	Minimum air clearance - on top	50 mm
LED lighting	•	Width	680 mm
Rear rollers	•		
Single bottle holders	2		
SmartTouch control panel	•		
Spill proof removable bins	•		

**Variable Temp Compartment**

Bottle chill mode	•
-------------------	---

**Warranty**

Parts and labour	2 years
Sealed system parts only	5 years

SKU	26193
-----	-------

The product dimensions and specifications in this page apply to the specific product and model. Under our policy of continuous improvement, these dimensions and specifications may change at any time. You should therefore check with Fisher & Paykel's Customer Care Centre to ensure this page correctly describes the model currently available. © Fisher & Paykel Appliances Ltd 2020

**Other product downloads available at fisherpaykel.com**

- [↓](#) 2D-DWG Freestanding Refrigerator Freezer
- [↓](#) 2D-DXF Freestanding Refrigerator Freezer
- [↓](#) Data Sheet Freestanding Refrigerator Freezer
- [↓](#) Service & Warranty

- [↓](#) Installation Guide
- [↓](#) User Guide
- [↓](#) User & Installation Guide ActiveSmart Refrigerator

**Where applicable:**

All appliances use energy, and energy usage typically generates carbon emissions. **Fisher & Paykel Appliances' In-use Energy Carbon Emissions Estimate** indicates carbon emissions from a product's in-use energy. This is calculated either annually or per cycle, using the product's market-specific energy label energy consumption data multiplied by the carbon emissions factor for energy in your country or region.

Our In-use Energy Carbon Emissions Estimate is designed to assist customers in making informed purchasing decisions when comparing different Fisher & Paykel products. For example, a heat pump dryer typically has a lower In-use Energy Carbon Emissions Estimate than a vented dryer.



**A PEACE OF MIND SALE**  
**24 Hours 7 Days a Week Customer Support**  
 T +65 6741 0777 Wwww.fisherpaykel.com

**Freezer Features**

Bottle chill	•
Door alarm	•
Fast freeze	•
Large plastic bins	•
Slide Out Pastry Tray	•

**Performance**

ActiveSmart™ Foodcare	•
Adaptive defrost	•
Frost free	•
Inverter controlled compressor	•
R600a refrigerant	•

**Product dimensions**

Depth	695 mm
Height	1720 mm