

90cm Series 7 Integrated French Door Refrigerator Freezer

Series 7 | Integrated

Panel Ready



This large capacity refrigerator with bottom freezer seamlessly integrates into your kitchen, fitting flush into your cabinetry.

- ActiveSmart™ technology helps keep food fresher for longer by constantly maintaining the ideal temperature.
- Customise with your own kitchen cabinetry or purchase our stainless steel door panel accessory

- Spacious bottom freezer with full extension drawer gives easy access to frozen goods.

DIMENSIONS

Height	1798 mm
Width	896 mm
Depth	610 mm

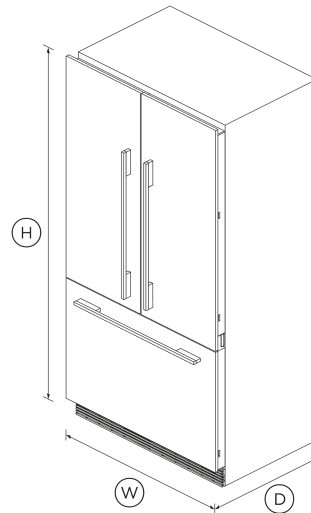

FEATURES & BENEFITS

ACTIVESMART™ FOODCARE

ActiveSmart™ Foodcare learns how you live. It's the technology that understands how you use your refrigerator and adjusts the temperature, airflow and humidity inside to help keep food fresher for longer.

Simple Storage

This refrigerator is designed to make it simple for you to store, access and remove food. Storage bins give you full access inside when they're pulled open and can be easily removed to clean. Our flexible shelving also gives you more storage options.

Clever Energy

Your fridge adapts to daily use by cooling and defrosting only when needed. This ActiveSmart™ technology means better energy efficiency without compromising on food care.

Easy Cleaning

Spill-safe secure glass shelves easily capture any drips or leaks and prevent them from falling on items below.

Simple Installation

Our Integrated products are easy to install, whether you are renovating your kitchen or designing a new one. Adjustable front and rear feet allow for uneven floors alongside adjustable door panels that can be customised to match your kitchen. These models are designed to easily slide into place as separate units - a perfect fit for European design kitchens.

DESIGN QUALITY

Our refrigerators are designed and built using quality materials. We use real stainless steel, and solid glass for shelving.

SPECIFICATIONS

Accessories (sold separately)

Handle kit Classic	AHCLRD90A
Handle kit Contemporary round, aluminium	AHS-ASBI-A
Handle kit Contemporary square fine, aluminium	AHD5RD90A
Handle kit Contemporary square fine, black	AHD5RD90AB
Handle kit Professional round flush	AHP3RD90A

Capacity	
Total gross capacity	525 L
Volume	476 L
Volume freezer	145 L
Volume refrigerator	331 L

Consumption	
Energy rating	3.5 star

Features	
Adjustable door shelves	6
Adjustable glass cantilevered shelves	•
Adjustable glass shelves	3
Covered door shelves	2
Door alarm	•
Fruit and vegetable bins	2
Full extension runners	•
LED lighting	•
Smart appliance	•
SmartTouch control panel	•
Soft close doors	•
Stackable bottle holders	4

Freezer Features	
Bottle chill	•
Door alarm	•
Fast freeze	•
Freezer bins	2

Large plastic bins	•
LED Lighting	•
Slide Out Pastry Tray	•
Small plastic bins	•

Performance	
ActiveSmart™ Foodcare	•
Adaptive defrost	•
Frost free freezer	•
Humidity control system	•
Inverter controlled compressor	•
Sabbath mode	•

Power requirements	
Supply voltage	230 V

Product dimensions	
Depth	610 mm
Height	1798 mm
Width	896 mm

Variable Temp Compartment	
Bottle chill mode	•

Warranty	
Sealed system parts only	5 years

SKU **26522**

The product dimensions and specifications in this page apply to the specific product and model. Under our policy of continuous improvement, these dimensions and specifications may change at any time. You should therefore check with Fisher & Paykel's Customer Care Centre to ensure this page correctly describes the model currently available. © Fisher & Paykel Appliances Ltd 2020

Other product downloads available at fisherpaykel.com

- [↓](#) 2D-DWG Integrated French Door Fridge Freezer
- [↓](#) 2D-DXF Integrated French Door Fridge Freezer
- [↓](#) Archicad Integrated French Door Fridge Freezer
- [↓](#) Data Sheet Integrated French Door Fridge Freezer
- [↓](#) Energy Label
- [↓](#) Service & Warranty
- [↓](#) Planning Guide Integrated French Door Fridge Freezer
- [↓](#) Revit French Door Refrigerator Freezer
- [↓](#) Rhino French Door Refrigerator Freezer
- [↓](#) Rhino French Door Refrigerator Freezer
- [↓](#) Rhino French Door Refrigerator Freezer with Door Panel and Contemporary Square Fine Black Handle
- [↓](#) Rhino French Door Refrigerator Freezer
- [↓](#) Rhino French Door Refrigerator Freezer
- [↓](#) SketchUp French Door Refrigerator Freezer
- [↓](#) SketchUp French Door Refrigerator Freezer
- [↓](#) SketchUp French Door Refrigerator Freezer with Door Panel and Contemporary Square Fine Black Handle
- [↓](#) SketchUp French Door Refrigerator Freezer
- [↓](#) SketchUp French Door Refrigerator Freezer
- [↓](#) Sketchup Integrated French Door Fridge Freezer
- [↓](#) User Guide Integrated Refrigerator Freezer

Where applicable:

All appliances use energy, and energy usage typically generates carbon emissions. **Fisher & Paykel Appliances' In-use Energy Carbon Emissions Estimate** indicates carbon emissions from a product's in-use energy. This is calculated either annually or per cycle, using the product's market-specific energy label energy consumption data multiplied by the carbon emissions factor for energy in your country or region.

Our In-use Energy Carbon Emissions Estimate is designed to assist customers in making informed purchasing decisions when comparing different Fisher & Paykel products. For example, a heat pump dryer typically has a lower In-use Energy Carbon Emissions Estimate than a vented dryer.



A PEACE OF MIND SALE
24 Hours 7 Days a Week Customer Support
T 1300 650 590 W www.fisherpaykel.com