

30" Series 7 Contemporary Self-Cleaning Oven, 9 Function

Series 7 | Contemporary

Stainless Steel

- Non-tip, full-extension shelves for safe removal of hot dishes

DIMENSIONS

Height	27 1/16 "
Width	29 29/32 "
Depth	23 29/32 "

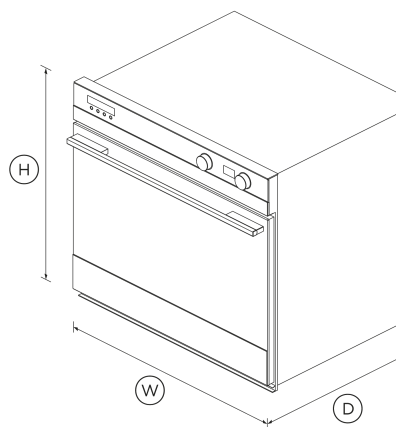

The self-clean function breaks down food residue at a very high temperature, leaving a light ash that's easily removed with a damp cloth. For best results, wipe down the inside of your oven door before you use the self-clean function.

Sized To Suit

Designed for multi-shelf cooking, this is one of the largest built-in ovens on the market providing 4.1 cu.ft of total capacity. The higher internal cavity allows you to fit a large casserole dish, the family roast and a pie for dessert.

Safe And Sound

The CoolTouch door with triple glazing and cooling system is safe to touch from the outside, protecting your hands and the surrounding cabinetry. Getting large dishes in and out of the oven is a breeze with full telescopic sliding shelves that stay perfectly steady – even when pulled all the way out.

Complementary Design

With their premium handle styling and stainless steel finish, our built-in ovens are designed to match the rest of Fisher & Paykel's kitchen appliance family.

Cooking Flexibility

This built-in oven has nine functions with pre-set temperatures, including Bake, Classic Bake and Aero™ Broil allowing you to use a variety of cooking styles.

SPECIFICATIONS

Accessories (sold separately)

Handle kit Contemporary round, aluminium	Part number 81672
--	----------------------

Capacity

Shelf positions	8
-----------------	---



This built-in oven has a large capacity and multiple functions, to ensure every dish is cooked to perfection.

- 4.1 cu ft total capacity
- Nine oven functions including Aero™ Broil and Aero™ Pastry
- High-temperature self-cleaning function breaks down food residue for an easy clean

FEATURES & BENEFITS

Even Cooking

Our built-in ovens feature AeroTech™ - a technology that circulates heat evenly, ideal for multi-shelf cooking.

Self Cleaning

<p>Total capacity 4 cu ft</p> <hr/> <p>Cleaning</p> <ul style="list-style-type: none"> Acid resistant graphite enamel • Pyrolytic self-clean • Removable oven door • Removable shelf runners • <hr/> <p>Controls</p> <ul style="list-style-type: none"> Audio feedback • Automatic cooking/minute timer • Automatic pre-set temperatures • Celsius/Fahrenheit temperature • Electronic capacitive touch controls • Electronic clock • Electronic oven control • Intuitive touchscreen display • <hr/> <p>Functions</p> <ul style="list-style-type: none"> Aero Broil • Aero Pastry • Aero™ Bake • Bake • Classic bake • Dehydrate • Maxi Broil • Number of functions 9 Pyrolytic self-clean • 	<ul style="list-style-type: none"> True Aero • Warm • <hr/> <p>Performance</p> <ul style="list-style-type: none"> AeroTech™ technology • Automatic rapid pre-heat • Broil power 4400 W <hr/> <p>Power Requirements</p> <ul style="list-style-type: none"> Amperage 19.5 A Supply frequency 60 Hz Supply voltage 120 - 240 V <hr/> <p>Product Dimensions</p> <ul style="list-style-type: none"> Depth 23 29/32 " Height 27 1/16 " Width 29 29/32 " <hr/> <p>Safety</p> <ul style="list-style-type: none"> Balanced oven door • Catalytic venting system • Control panel key lock • CoolTouch door • Non-tip shelves • <hr/> <p>Warranty</p>	<p>Parts and labor 2 years</p> <hr/> <p>SKU 81512</p> <hr/> <p>The product dimensions and specifications in this page apply to the specific product and model. Under our policy of continuous improvement, these dimensions and specifications may change at any time. You should therefore check with Fisher & Paykel's Customer Care Centre to ensure this page correctly describes the model currently available. © Fisher & Paykel Appliances Ltd 2020</p> <p>Other product downloads available at fisherpaykel.com</p> <ul style="list-style-type: none"> ↓ 2D-DWG Oven ↓ 2D-DXF Oven ↓ Archicad Oven ↓ Data Sheet Oven ↓ Service & Warranty ↓ Installation Guide EN / Guide d'installation FR ↓ Revit Oven ↓ Sketchup Oven ↓ User Guide EN <p>Where applicable:</p> <p>All appliances use energy, and energy usage typically generates carbon emissions. Fisher & Paykel Appliances' In-use Energy Carbon Emissions Estimate indicates carbon emissions from a product's in-use energy. This is calculated either annually or per cycle, using the product's market-specific energy label energy consumption data multiplied by the carbon emissions factor for energy in your country or region.</p>
---	--	--

Our In-use Energy Carbon Emissions Estimate is designed to assist customers in making informed purchasing decisions when comparing different Fisher & Paykel products. For example, a heat pump dryer typically has a lower In-use Energy Carbon Emissions Estimate than a vented dryer.



A PEACE OF MIND SALE
24 Hours 7 Days a Week Customer Support
T 1.888.936.7872 W www.fisherpaykel.com