

# Freestanding French Door Refrigerator Freezer, 36", 20.1 cu ft, Ice

Series 7 | Contemporary

Stainless Steel | French hinge



Designed for those who need plenty of flexible space. Counter-depth design, with a stylish stainless steel finish for a seamless look.

- ActiveSmart™ Foodcare technology helps keep food fresher for longer
- Counter-depth design with flat door, for streamlined look
- Brushed metal handles

## DIMENSIONS

Height	70 15/32 "
Width	35 7/16 "
Depth	27 3/8 "

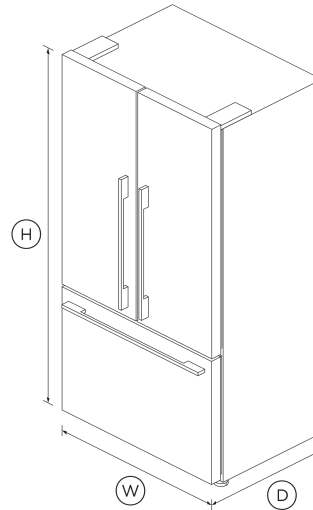

## FEATURES & BENEFITS

### Activesmart™ Foodcare

This refrigerator freezer adapts to daily use by cooling and defrosting only when needed. ActiveSmart™ Foodcare technology uses energy efficiently without compromising on food care.

### Flexible Storage

Adjustable shelves and door storage give you plenty of room to stack and pack all your groceries. Storage bins give you full access inside when they're pulled open and can be easily removed to clean.

### Humidity Control

Your fruit and veges need different environments to stay fresh. Humidity control in each storage bin allows you to maintain a microclimate that helps keep food fresher for longer.

### Design Quality

Our fridges are designed and built using quality materials. We use real stainless steel on our fridges and solid glass for shelving.

### Internal Ice Maker

Fresh ice is always available for you in a dedicated freezer bin. Simply turn it off to free up freezer space or during busy times, you can boost ice production by up to 30%.

### Easy Cleaning

Spill-safe secure glass shelves easily capture any drips or leaks and prevent them from falling on items below.

### Easy to use

The SmartTouch control panel has been designed to be intuitive for ease to use, and is conveniently placed near the front of the fridge.

## SPECIFICATIONS

### Accessories (sold separately)

Water filter replacement **847200 - FWC3**

### Capacity

Total gross capacity	<b>20.1 cu ft</b>
Volume freezer	<b>5.5 cu ft</b>
Volume refrigerator	<b>14.6 cu ft</b>

Ice Boost	•
Large plastic bins	•
LED Lighting	•

The product dimensions and specifications in this page apply to the specific product and model. Under our policy of continuous improvement, these dimensions and specifications may change at any time. You should therefore check with Fisher & Paykel's Customer Care Centre to ensure this page correctly describes the model currently available. © Fisher & Paykel Appliances Ltd 2020

**Consumption**

Energy usage	<b>532kWh/year</b>
In-use energy carbon emissions estimate	<b>65.6kgCO<sub>2</sub>e/year</b>

**Performance**

ActiveSmart™ Foodcare	•
Adaptive defrost	•
Frost free freezer	•
Humidity control system	•
Inverter controlled compressor	•
Sabbath mode	•

**Other product downloads available at fisherpaykel.com**

- [↓](#) Energy Label
- [↓](#) Service & Warranty
- [↓](#) Water Filter Replacement Instructions & Installation Guide EN
- [↓](#) Guide d'installation - Instructions de Remplacement du Filtre à Eau FR
- [↓](#) Installation Guide
- [↓](#) Guide d'installation FR
- [↓](#) User Guide
- [↓](#) Guide d'utilisation FR

**Features**

Adjustable door shelves	<b>6</b>
Adjustable glass shelves	<b>3</b>
Covered door shelves	<b>2</b>
Deli storage bins	<b>2</b>
Door alarm	•
Fruit and vegetable bins	<b>2</b>
LED lighting	•
Smart appliance US CA	•
SmartTouch control panel	•
Soft close doors	•
Stackable bottle holders	<b>4</b>
Wi-Fi connectivity	•

**Product dimensions**

Depth	<b>27 3/8 "</b>
Height	<b>70 15/32 "</b>
Width	<b>35 7/16 "</b>

**Where applicable:**

All appliances use energy, and energy usage typically generates carbon emissions. **Fisher & Paykel Appliances' In-use Energy Carbon Emissions Estimate** indicates carbon emissions from a product's in-use energy. This is calculated either annually or per cycle, using the product's market-specific energy label energy consumption data multiplied by the carbon emissions factor for energy in your country or region.

**Warranty**

Parts and labor	<b>2 years</b>
Sealed system parts & labor	<b>additional 3 years</b>

Our In-use Energy Carbon Emissions Estimate is designed to assist customers in making informed purchasing decisions when comparing different Fisher & Paykel products. For example, a heat pump dryer typically has a lower In-use Energy Carbon Emissions Estimate than a vented dryer.

**Freezer Features**

Automatic ice maker	•
Bottle chill	•
Door alarm	•
Fast freeze	•
Ice bin and scoop	•

SKU	26306
-----	-------



**A PEACE OF MIND SALE**

24 Hours 7 Days a Week Customer Support

T 1.888.936.7872 W [www.fisherpaykel.com](http://www.fisherpaykel.com)