

Series 11, Integrated Tall Double DishDrawer Dishwasher

Series 11 | Integrated

Panel Ready



<p>Integrates seamlessly into kitchen cabinetry. Each drawer features a premium stainless steel interior and operates independently, for flexible washing.</p>

- Eight wash cycles from Heavy to Light, including Auto, 60min and Glassware
- Tall top drawer fits full-size dinner plates up to 12 1/4 inches, with flexible racking for large cookware

- With soft-close drawers, and knock to pause convenience
- Wi-Fi capability and a SmartHQ™ app for remote control and notifications

DIMENSIONS

Height	34 - 36 3/8 "
Width	23 9/16 "
Depth	21 3/4 "

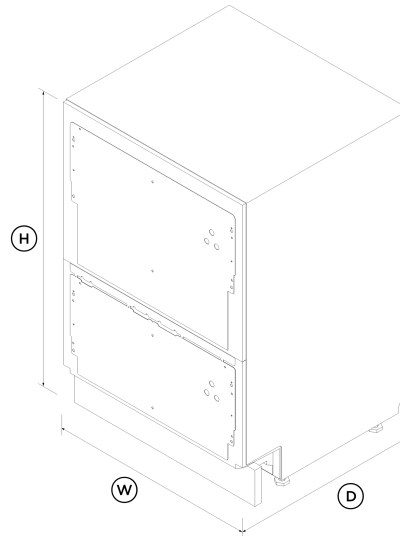

FEATURES & BENEFITS

Seamless Integration

Install your DishDrawer™ Dishwasher into an existing kitchen space or integrate into kitchen cabinetry. The touch-sensitive control panel is located inside this Integrated model, leaving an uninterrupted exterior that blends seamlessly with surrounding cabinetry.

Ease Of Use

DishDrawer™ Dishwashers are beautiful to use with soft-close drawers. The tall top drawer fits your larger plates and dishes up to 12 1/4 inches, while the bottom drawer is ideal for small washes. Flexible racking includes height-adjustable cup racks and wine glass supports.

True Half Load

Both drawers fit a true half load. Each drawer operates independently, so you can wash one load while stacking the other drawer, or wash simultaneously on separate cycles.

Flexible Wash Options

Eight wash programs including Auto, 60min and Glassware, while modifiers such as Sanitize, Dry+ and Quiet provide added wash flexibility. The Quiet wash modifier reduces the noise on some cycles while maintaining performance - perfect for late night washing.

Design Quality

Every detail has been carefully crafted using quality materials, from the easy-to-clean stainless steel interior to the spray arm sensor that detects jams for increased wash confidence.

Knock To Pause

For ease-of-use, these DishDrawer™ Dishwashers have a knock to pause function. A knock on the front panel will pause the dishwasher, which can be restarted by using the start button.

Quiet Performer

Running at a low decibel rating of 44dBA, these DishDrawer™ Dishwashers do their job without making a fuss. The combination of intelligent technology and simple mechanics means greater reliability and excellent wash performance.

SPECIFICATIONS

Accessories (included)

- Cutlery basket •
- Kickstrip **true**
- Knife clip and multipurpose clip •

Accessories (sold separately)

- Door panel stainless steel **ADDD24DTPX**
- Handle kit Classic **AHCL-DDDW-24X**
- Handle kit Contemporary round, aluminium **AHS-OBDD-60S**
- Handle kit Contemporary square fine, aluminium **AHD5-OBDD-60SX**
- Handle kit Contemporary square fine, black **AHD5-OBDD-60SB**
- Handle kit Contemporary square, aluminium **AHD3-OBDD-60S**
- Handle kit Professional round flush **AHP3-DWDD-SX**
- Handle kit Professional round flush, Brass off-stands **AHP3DDD24BA**
- Handle kit Professional round flush, Dark Copper off-stands **AHP3DDD24DC (2 handles required)**

Capacity and loading

- Accommodates round plates up to **12.25" (top) 11" (bottom)**
- Adjustable height, foldable cupracks •

- Fold down tines •
- Pitch adjustable tines •
- Place settings **14**
- Place settings **14**
- Wine glass supports with stemware grippers •

Consumption

- Energy usage **239kWh/year**
- In-use energy carbon emissions estimate **29.5kgCO2e/year**
- Water usage (per wash cycle) **3.7 gal**

Controls

- Electronic fault/Diagnostic indicator •
- End of cycle beeps •
- Energy saving delay start option of up to 12 hours •
- Internal wash selector •
- Intuitive capacitive touch controls •
- Keylock •
- Knock to pause •
- Rinse aid indicator light •
- Smart appliance •
- Spray arm sensing •

Features

- Built-in water softener •
- Fan assisted drying •
- Flood protection •
- Flow through detergent dispenser •

- Internal tub material **Stainless steel**
- Quiet operation •
- SmartDrive™ technology •
- Soft close drawer •

Performance

- Noise on standard cycle top drawer **44 dBA**

Power requirements

- Amperage **10A**
- Rated current **15 A**
- Supply frequency **60Hz**
- Supply voltage **100 - 120V**

Product dimensions

- Depth **21 3/4 "**
- Height **34 - 36 3/8 "**
- Width **23 9/16 "**

Warranty

- Parts and labor **Limited 2 years**

Wash Program Modifiers

- Dry + •
- Quiet •
- Sanitise •

Wash modifiers **3**

Wash Programs

- 60 min •
- Auto •
- Eco •
- Glassware •
- Heavy •
- Light •
- Medium •
- Rinse •
- Wash programs **8**

Water connection

- Inlet water temperature **max 140 °F**
- Supplied hose to suit 3/8" (9mm) male compression fitting •
- Water pressure **100kPa - 1000kPa**
- Water supply **3/8" to suit Male Compression Fitting**

SKU **82163**

The product dimensions and specifications in this page apply to the specific product and model. Under our policy of continuous improvement, these dimensions and specifications may change at any time. You should therefore check with Fisher & Paykel's Customer Care Centre to ensure this page correctly describes the model currently available. © Fisher & Paykel Appliances Ltd 2020

Other product downloads available at fisherpaykel.com

- [↓](#) Wash Program Data Sheet
- [↓](#) 2D-DWG Integrated Double DishDrawer™ Dishwasher
- [↓](#) 2D-DXF Integrated Double DishDrawer™ Dishwasher
- [↓](#) Archicad Integrated Double DishDrawer™ Dishwasher
- [↓](#) Data Sheet
- [↓](#) Energy Label Double DishDrawer™ Dishwasher
- [↓](#) Service & Warranty
- [↓](#) Planning Guide Integrated Double DishDrawer™
- [↓](#) Planning Guide Professional Style Dial/Handle Accessories
- [↓](#) Revit Integrated Double DishDrawer™ Dishwasher
- [↓](#) Rhine Integrated Double DishDrawer™ Dishwasher
- [↓](#) Sketchup Integrated Double DishDrawer™ Dishwasher
- [↓](#) Specification Guide
- [↓](#) User Guide DishDrawer™ Dishwasher EN
- [↓](#) Guide d'utilisation FR
- [↓](#) Wash Program Data Sheet EN

Where applicable:

All appliances use energy, and energy usage typically generates carbon emissions. **Fisher & Paykel Appliances' In-use Energy Carbon Emissions Estimate** indicates carbon emissions from a product's in-use energy. This is calculated either annually or per cycle, using the product's market-specific energy label energy consumption data multiplied by the carbon emissions factor for energy in your country or region.

Our In-use Energy Carbon Emissions Estimate is designed to assist customers in making informed purchasing decisions when comparing different Fisher & Paykel products. For example, a heat pump dryer typically has a lower In-use Energy Carbon Emissions Estimate than a vented dryer.



A PEACE OF MIND SALE
 24 Hours 7 Days a Week Customer Support
 T 1.888.936.7872 W www.fisherpaykel.com