

30" Series 7 Professional Self-Cleaning Double Oven, 10 Function

Series 7 | Professional

Stainless Steel



Choose maximum capacity, combining two independent ovens so you can cook multiple dishes simultaneously.

- 4.1 + 4.1 cu ft total capacity across two oven cavities
- 10 functions in each oven including Roast and Aero™ Pastry
- High-temperature self-cleaning function breaks down food residue for an easy clean

- Non-tip, full-extension shelves for safe removal of hot dishes

DIMENSIONS

Height	48 1/2 "
Width	29 3/4 "
Depth	23 5/16 "

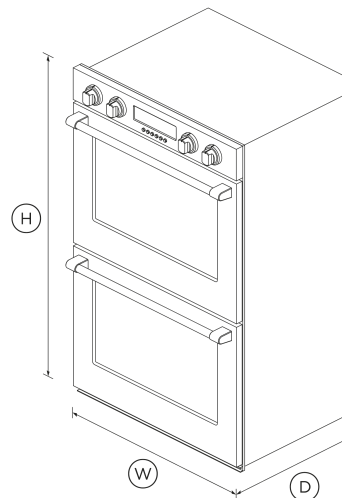

FEATURES & BENEFITS

Cooking Flexibility

This built-in oven has 10 functions with pre-set temperatures, including Roast, Pastry Bake and Maxi Broil allowing you to use a variety of cooking styles.

Even Cooking

A digital microprocessor monitors the temperature to ensure precise heat and a four-way convection system creates even heat distribution throughout the oven, ideal for multi-shelf cooking.

Sized To Suit

This is one of the largest built-in ovens on the market providing 8.2 cu ft total capacity across two oven cavities allowing you to fit a large casserole dish, the family roast and a pie for dessert.

Self Cleaning

The self-clean function breaks down food residue at a very high temperature, leaving a light ash that's easily removed with a damp cloth. For best results, wipe down the inside of your oven door before you use the self-clean function.

Information At A Glance

Halo illuminated dials provide information at a glance. White - heating up; orange - temperature is reached; red - self-cleaning mode. Three halogen lights and the large oven window creates excellent visibility of what's cooking.

Safe And Sound

The CoolTouch door with triple glazing and cooling system is safe to touch from the outside, protecting your hands and the surrounding cabinetry.

SPECIFICATIONS

Accessories (included)

Full extension sliding shelves **5 sets**

Capacity

Shelf positions **8**
Total capacity **8.2 cu ft**

<p>Usable capacity 7.2 cu ft</p> <hr/> <p>Cleaning</p> <ul style="list-style-type: none"> Acid resistant graphite enamel • Pyrolytic self-clean • Removable oven door • Removable shelf runners • <hr/> <p>Controls</p> <ul style="list-style-type: none"> Audio feedback • Automatic cooking/minute timer • Automatic pre-set temperatures • Celsius/Fahrenheit temperature • Delay start • Electronic clock • Electronic oven control • Halogen lights • Intuitive touchscreen display • LED display • Turned stainless capacitive touch buttons with illuminated halos • <hr/> <p>Functions</p> <ul style="list-style-type: none"> Bake • Broil • Convection bake • Convection Broil • Convection pastry • Maxi Broil • 	<ul style="list-style-type: none"> Maxi Grill • Number of functions 10 Pastry Bake • Pastry Bake with Pizza mode • Pyrolytic self-clean • Roast • True convection • Warm • <hr/> <p>Performance</p> <ul style="list-style-type: none"> AeroTech™ technology • Automatic rapid pre-heat • Broil power 4400 W <hr/> <p>Power Requirements</p> <ul style="list-style-type: none"> Amperage 50 A Supply frequency 60 Hz Supply voltage 120 / 240 V <hr/> <p>Product Dimensions</p> <ul style="list-style-type: none"> Depth 23 5/16 " Height 48 1/2 " Width 29 3/4 " <hr/> <p>Safety</p> <ul style="list-style-type: none"> ADA compliant • Control panel key lock • 	<ul style="list-style-type: none"> CoolTouch door • Non-tip shelves • Safety thermostat • <hr/> <p>Warranty</p> <ul style="list-style-type: none"> Parts and labor 2 years <hr/> <p>SKU 81831</p> <hr/> <p>The product dimensions and specifications in this page apply to the specific product and model. Under our policy of continuous improvement, these dimensions and specifications may change at any time. You should therefore check with Fisher & Paykel's Customer Care Centre to ensure this page correctly describes the model currently available. © Fisher & Paykel Appliances Ltd 2020</p> <p>Other product downloads available at fisherpaykel.com</p> <ul style="list-style-type: none"> ↓ 2D-DWG Double Oven ↓ 2D-DXF Double Oven ↓ Data Sheet Double Oven ↓ Service & Warranty ↓ Installation Guide ↓ Quick Start Guide EN ↓ User Guide EN <p>Where applicable:</p>
---	---	---

All appliances use energy, and energy usage typically generates carbon emissions. **Fisher & Paykel Appliances' In-use Energy Carbon Emissions Estimate** indicates carbon emissions from a product's in-use energy. This is calculated either annually or per cycle, using the product's market-specific energy label energy consumption data multiplied by the carbon emissions factor for energy in your country or region.

Our In-use Energy Carbon Emissions Estimate is designed to assist customers in making informed purchasing decisions when comparing different Fisher & Paykel products. For example, a heat pump dryer typically has a lower In-use Energy Carbon Emissions Estimate than a vented dryer.



A PEACE OF MIND SALE
24 Hours 7 Days a Week Customer Support
T 1.888.936.7872 W www.fisherpaykel.com