

90cm Series 7 Integrated French Door Refrigerator Freezer, Ice & Water

Series 7 | Integrated

Panel Ready



This large capacity refrigerator with bottom freezer seamlessly integrates into your kitchen, fitting flush into your cabinetry.

- ActiveSmart™ technology helps keep food fresher for longer by constantly maintaining the ideal temperature.
- Customise with your own kitchen cabinetry* or purchase our stainless steel door panel accessory
- Water dispenser available with stainless steel door panel accessory

- Spacious bottom freezer with full extension drawer and ice maker with boost function

DIMENSIONS

Height	1797 mm
Width	896 mm
Depth	610 mm

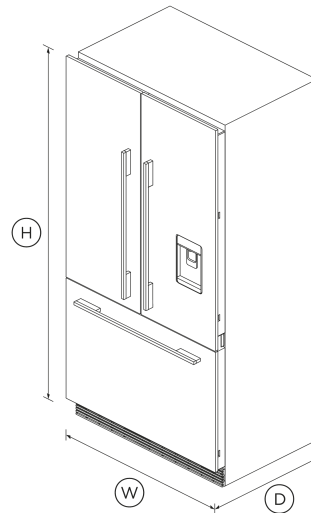

FEATURES & BENEFITS

Activesmart™ Foodcare

ActiveSmart™ Foodcare learns how you live. It's technology which understands how you use your refrigerator and adjusts temperature, airflow and humidity inside to help keep food fresher for longer.

Simple Storage

This refrigerator is designed to make it simple for you to store, access and remove food. Storage bins give you full access inside when they're pulled open and can be easily removed to clean. Our flexible shelving also gives you more storage options.

Ice Maker

Fresh ice is always available for you in a dedicated freezer bin. Simply turn it off to free up freezer space or during busy times, you can boost ice production by up to 30%.

Water On Tap

The slimline dispenser makes it easy to fill almost any sized jug or vessel with cool filtered water and doesn't take up any storage space in your refrigerator. You'll need to purchase our stainless steel door panel in order to use the water dispenser.

Easy Cleaning

No more permanent dirty marks with our EZKleen feature for stainless steel refrigerators. Anti-fingerprint coating means you simply wipe clean any marks. Spill-safe secure glass shelves easily capture any drips or leaks.

Clever Energy

Your refrigerator adapts to daily use by cooling and defrosting only when needed. This ActiveSmart™ technology means better energy efficiency without compromising on food care.

SPECIFICATIONS

Accessories (sold separately)

Door panel set stainless steel	RD90AU
Handle kit Classic	AHCLRD90A
Handle kit Contemporary round, aluminium	AHS-ASBI-A
Handle kit Contemporary square fine, aluminium	AHD5RD90A
Handle kit Contemporary square fine, black	AHD5RD90AB

Handle kit Professional round flush	AHP3RD90A
Water filter replacement	847200 - FWC3

Capacity

Total gross capacity	525 L
Volume freezer	145 L
Volume refrigerator	331 L

Consumption

Energy rating	E
Energy usage	304kWh/year
In-use energy carbon emissions estimate	93.9kgCO2e/year

Features

Adjustable door shelves	6
Adjustable glass shelves	3
Covered door shelves	2
Deli storage bins	1
Door alarm	•
Fruit and vegetable bins	2
LED lighting	•
Smart appliance	•
SmartTouch control panel	•
Soft close doors	•
Spill proof removable bins	•
Stackable bottle holders	4
Ultra slim water dispenser	•

Freezer Features

- Automatic ice maker
- Bottle chill
- Door alarm
- Fast freeze
- Ice bin and scoop
- Large plastic bins

Performance

- ActiveSmart™ Foodcare
- Adaptive defrost
- Frost free freezer
- Humidity control system
- Sabbath mode

Product dimensions

Depth	610 mm
Height	1797 mm
Width	896 mm

Variable Temp Compartment

- Bottle chill mode

Warranty

Parts and labour	5 years
Sealed system parts only	5 years

SKU 26658

The product dimensions and specifications in this page apply to the specific product and model. Under our policy of continuous improvement, these dimensions and specifications may change at any time. You should therefore check with Fisher & Paykel's Customer Care Centre to ensure this page correctly describes the model currently available. © Fisher & Paykel Appliances Ltd 2020

Other product downloads available at fisherpaykel.com

- [↓ Product Information Sheet](#)
- [↓ 2D-DWG Integrated French Door Fridge Freezer](#)
- [↓ 2D-DXF Integrated French Door Fridge Freezer](#)
- [↓ Archicad Integrated French Door Fridge Freezer](#)
- [↓ Data Sheet Integrated French Door Fridge Freezer](#)
- [↓ Declaration of Conformity Refrigeration with WiFi Capability](#)
- [↓ Energy Label Integrated French Door Refrigerator Freezer](#)
- [↓ Service & Warranty](#)
- [↓ Water Filter Replacement Instructions & Installation Guide EN](#)
- [↓ Product Fiche](#)
- [↓ Planning Guide Integrated French Door Fridge Freezer](#)
- [↓ Revit Integrated French Door Fridge Freezer](#)
- [↓ Sketchup Integrated French Door Fridge Freezer](#)

Where applicable:

All appliances use energy, and energy usage typically generates carbon emissions. **Fisher & Paykel Appliances' In-use Energy Carbon Emissions Estimate** indicates carbon emissions from a product's in-use energy. This is calculated either annually or per cycle, using the product's market-specific energy label energy consumption data multiplied by the carbon emissions factor for energy in your country or region.

Our In-use Energy Carbon Emissions Estimate is designed to assist customers in making informed purchasing decisions when comparing different Fisher & Paykel products. For example, a heat pump dryer typically has a lower In-use Energy Carbon Emissions Estimate than a vented dryer.



A PEACE OF MIND SALE
24 Hours 7 Days a Week Customer Support

T 1800 625174 W www.fisherpaykel.com